

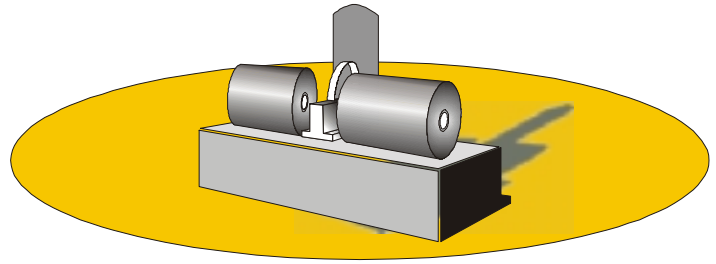

21st



CENTURY
MECHANISM

21st Century Juke Box Range

Version 3

SOUND LEISURE LTD.
39 INGS ROAD, LEEDS, LS9 9EW, YORKSHIRE,
ENGLAND
TEL: 0113 2175000 FAX: 0113 2175003
WWW.SOUND-LEISURE.COM
Email: tech@soundl.force9.uk

CONTENTS

	Page No.
1 Introduction	4
2.1 Master Reset	5
2.2 System Features.....	5
3 Installation Requirements.	6
3.1 Taking Delivery.....	6
3.2 Taking Machine to Site.....	6
3.3 Jukebox/Hideaway Unit.....	6
3.4 When On Site.....	7
3.5 Wallbox.....	7
3.6 System Connection.....	7
3.7 Cable Requirements.....	8
3.8 Coin Meter.....	8
3.8.1 Series 3 Wallbox.....	8
3.8.2 Series 2 Wallbox.....	8
3.8.3 "Jukebox ".....	8
3.9 Jukebox/Hideaway/Wallbox Sample Wiring.....	9
3.10 Mains Lead	9
4. Loading Discs.....	10
5. Important Notes.....	11
5.1 Compact Disc Care.....	11
5.2 Locks.....	11
5.3 Making a selection.....	12
5.4 Bubble Tubes.....	12
6 MK6 Mono Sound System.....	13
6.1 Warnings.....	13
6.2 MK6 Pre Amplifier. (Inputs and Volume Control).....	13
6.3 MK6 Power Amplifier.....	14
6.4 MK6 Slave Output.....	14
6.5 Karaoke.....	14
6.6 MK6 Control.....	15
6.7 MK6 Input Connection.....	16
7 MK7Stereo/Mono Sound System..(Inputs/LEDs)...	16
7.1 MK7 Pre Amplifier Setup.....(Volume Control).....	17
7.2 MK7 Slave Output.....	18
7.3 MK7 Power Amplifier.....	18
7.4 MK7 Controls.....	19
7.5 MK7 Input Connections.....	20
8. Speaker Wiring	21
9. GMT/BST Clock Adjustment.....	22
10. Background Music (BGM)	22

10.1	How it works - BGM.....	23
10.2	Constant BGM.....	23
10.3	Timed BGM.....	23
11.	Dil Switch Settings	24
11.1	Wallbox Switches.....	24
11.2	Hideaway/Jukebox.....	25
11.3	Credit Button.....	25
11.4	Set up Keys.....	26
12.	Programming	27
12.1	Programme Menu Structure.....	27
12.2	Standard Price of Play Table.....	28
12.3	Default Settings	29
	12.4.1 Entering Programme Mode.....	31
	12.4.2 Selecting a Program Menu	31
	12.4.3 Selecting a Level.....	31
	12.4.4 Editing Data in Level.....	31
	12.4.5 Exiting a Menu	32
	12.4.6 Exiting Programme Mode.....	32
	12.4.7 Example	32
12.5	Menu 5.....	35
12.6	Explanation of Tracks in a Row.....	35
12.7	Random Play.....	36
13.	Timed Functions....(BGM & Timed Free Play).....	37
14.	Track Lockout	38
15.	Infra Red Remote Control	39
16.	Disc Error Log	40
17.	Play Mechanism Set-up	40
17.1	Display format in Test Mode.....	40
17.2	Checking of Factory Settings.....	41
17.3	Re-alignment of 21st Century Mechanism.....	43
17.4	End Stop.....	44
17.5	Tower Opto Settings.....	44
17.6	Self Test Instructions.....	46
17.7	Laser Player Fitting/Alignment	49
18.	Disc Popularity (Basic System)	50
19.	Data Retrieval	51
20.	LED Bar Graph	54
21.	Title Rack Controller	55
22.	Lubrication	56
23.	Lens Cleaning	58

1. INTRODUCTION

This Manual covers the 21st Century range of Sound Leisure C.D. Jukeboxes and hideaway units.

The whole of the 21st Century range, which comprises a large number of different machines and systems, is built from a small set of building blocks, the main components of which are listed below:

1. The player mechanism.
2. A MK6 or MK7 audio amplifier.
3. The SLE 1000 main processor board.
4. The wallbox processor board.

In addition to the above list, various other system components exist. These include: coin mechanisms, selection keypads and displays, wallbox distribution boards, etc..

From the components in the above lists, three distinct sub-systems can be constructed which form the basis of all 21st Century equipment. These are:

1. A hideaway unit which consists of: the player mechanism, an SLE 1000 processor board and an audio amplifier, and a method of obtaining selections. These are designed for use in conjunction with a wallbox and, as the name implies, can be hidden, say, in a bar or a cellar.
2. A wallbox unit which displays and allows selections to be made in exchange for coin input. Up to three wallboxes can be connected to a jukebox or hideaway unit.
3. A jukebox which, effectively, combines the functionality of hideaway and wallbox units.

Although the information in this manual was correct at the time of printing, the manufacturer reserves the right to change it, without prior notice.

The contents of this manual may not be copied in part or full without prior consent from Sound Leisure Limited.

2.1 MASTER RESET

A Master Reset is used to reset all variables to do with the Play Mechanism. This needs to be carried out if for any reason the Play Mechanism or SLE 1000 Board is changed.

On an occasion when a Master Reset is required. The Credit Button situated on the SLE 1000 Board is used, as follows.

Hold down whilst turning the Machine on at the mains and keep depressed until the carriage has returned to disc position 100. This does not affect the Price of Play or Data held for Popularity Purposes or the BGM timers.

Master Reset / Eprom change.

If you are supplied with an updated Eprom version, then you will also need to perform a Master Reset.

2.2 SYSTEM FEATURES

* Extra Board Required.

30,60 and 80 Disc

Up to 2400 Track selections

Adjustable consecutive track plays (see tracks in a row explanation 12.6)

Selections played in selected order

Adjustable background music (B.G.M.) disc band

Adjustable foreground music (F.G.M.) disc band

7 day 24 hour real time clock (R.T.C.)

2 Individual timers

Individual start and stop times for each timer

Weekday/Weekend/Everyday / Individual days, enable for each timer

*Adjustable B.G.M. to F.G.M. volume (B.G.M.) Relay Output) via SLE 1014

Manual enable for B.G.M. operation (Dipswitch) available via SLE 1014

Programmable Random play (In minute)

Programmable price of play

Mechanical cash meter facility under software control

Microphone input with voice over activation and separate volume, bass and treble controls

Auxiliary line input socket for external B.G.M. unit.

600 ohm slave output with gain pre set

Provision for additional dual channel amplifier giving four channels in total

Retention of credit and selections on power fail situation. .

Full data retrieval system

New Feature ! New Feature ! New Feature !

E Prom version XX.9 onwards

With Dil switch 2 ON each power up of the Juke Box, will automatically select the ALLSOP 6 Brush Cleaning Disc, to keep the lens assembly free from dust.

This disc may be purchased direct from Telstar (code No 5920)

Please note that when using this feature the cleaning disc must be placed in location 129 for 30 select, 159 for 60 select and 179 for 80 select.

Note:- All Sound Leisure Machine are Tested and carry a C.E.mark.
(Certificate of Compliance)

Note: We would like to bring to your attention that, since 1992,
portable appliance testing is required and that a certificate of
compliance be issued.

3. INSTALLATION REQUIREMENTS

After unpacking the equipment, the following guide should assist you in
achieving a trouble free installation.

3.1 Taking Delivery of Machine

Turn the machine on

The display will show **trAnSit**.

The machine will automatically enter the service mode.

Open the door.

Remove the disc retaining/carry bar (on top of play mechanism), and
transit bar (left hand side of tower).

Turn DIL Switch 1 on SLE 1000 OFF. (The pick up arm will move up to
find the middle opto, this is to check that the disc retaining/carry bar
has been removed). If so the Mech will SYNC.

The display will show OPE (short for operate), and flash last disc and
track number played.

Insert C.Ds. into Mechanism (see section 4)

Loosen Transit Bolts/Clamps

Close the door.

The machine will exit the service mode and return to normal
operation.

3.2 Taking Machine to Site

Note DIL Switch 7 must be OFF on SLE 1000 Board

Open the door.

The Machine will switch to service mode.

The current disc will eject.

The pick up assembly will move to a central position.

Turn ON DIL Switch 1 on SLE 1000 Board.

The display will show **trAnSit**.

Install the disc retaining/carry bar(on top of play mechanism).

Install the transit bar (left hand side of tower).

Screw down Transit Bolts/clamps (on play mechanism).

Take the machine to site.

3.3 JUKEBOX/HIDEAWAY UNIT

Place the unit in the position in which it will be finally installed.

Ensure the location is dry and the equipment is set level.

We recommend an earth continuity test is carried out on the mains supply socket prior to use.

3.4 When on Site

Turn machine on.

The machine will show **trAnSit**.

The machine will automatically enter the service mode.

Open door.

Remove the disc retaining/carry bar (on top of play mechanism), and transit bar (left hand side of tower).

Loosen/remove transit bolts/clamps (on play mechanism).

Turn DIL Switch 1 OFF on SLE 1000 board.

The Mech will SYNC. i.e. at position 100.

The display will show OPE (short for operate), and flash last disc and track number played.

Close the door.

The machine will exit the service mode and return to normal operation.

3.5 WALLBOX

Firmly affix the wallbox hanging bracket so that on completion the coin input slot is at a height that can be reached with ease.

The wallbox, once hung on the bracket, is anchored with two bolts.
(M10)

Do not install Wallbox or wall hung Jukebox, in close proximity to any other unit emitting a strong magnetic field. Because coin input operation could be effected. Avoid installing units over heat sources. ie. Radiators etc.

The holes in the wallbox are oversized to facilitate its levelling.

3.6 SYSTEM CONNECTION

There are three wallbox connectors in the jukebox/hideaway system each having five terminals. These are located on a small circuit board labelled: 'Wall Box Distribution Board.'

Each wallbox must be **individually** wired back to the jukebox/hideaway unit.

3.7 CABLE REQUIREMENTS

The connection between individual wallboxes and a jukebox/hideaway unit is done via five cables.

Connectors are located within each piece of equipment. These connectors have terminals labelled 1,2,3,A and B.

Connect 1 to 1, 2 to 2, 3 to 3, A to A, B to B.

Cables connected to terminals 1 and 3 must have a minimum cross sectional area of 0.75mm² when connecting wallboxes up to 50 metres away and 1.5mm² when the wallbox is up to 100metres away.

Terminals 1 and 3 handle the wallbox low voltage supply. This voltage is supplied at the hideaway/jukebox as (14-0-14)V a.c.

Terminal 2 is the common ground return.

Terminals 'A' and 'B' are used for data transmission.

JB./HAU 'A' >>>>> WB 'A'

JB /HAU 'B' <<<<< WB 'B'

These two cables are signal lines and are not required to handle any great power, therefore much lighter gauge wire may be used.

NOTE: A minimum of 25V a.c. should be measured across terminals 1 and 3 at each wallbox to avoid any power supply problems.

3.8 COIN METER

A 12V d.c. meter **without an internal diode** may be connected to any C.D. wallbox or jukebox. Such meters are not polarised so they can be fitted either way round.

N.B. Use of meters with an in built diode could damage the processor boards.

3.8.1 SERIES 3 WALLBOX

Connect the meter to the two pin plug labelled MTR/CON 5 on the ACS 1043 wallbox processor board.

3.8.2 SERIES 2 WALLBOX

Locate the sentinel coin interface board. A meter may be connected to the two pin plug located at the top of this board.

3.8.3 JUKEBOX

Connect the meter to the two pin plug labelled Meter (CON6) on the SLE 1000 jukebox/hideaway board.

FIG 3.9 JUKEBOX / HIDEAWAY / WALLBOX SAMPLE WIRING

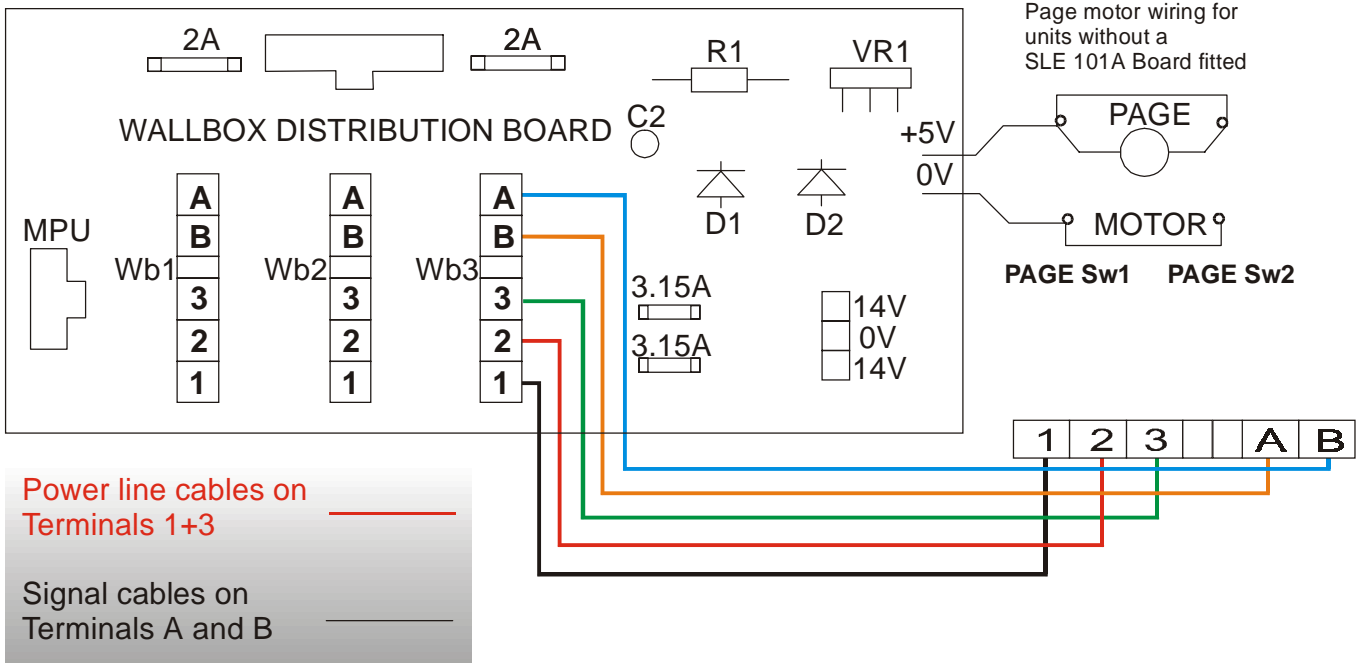

WALLBOX TERMINATION CONNECTOR LOCATED WITHIN WALLBOX.

3.10 Mains Lead.

It must be noted that the 240 v. Mains Lead supplied with all Sound Leisure equipment must not be extended over 2 metres. This is required by law.

4. LOADING DISCS

When standing in front of C.D. play mechanism, place the C.D's into rack with the picture face to the right and the clear face to the left.

Please ensure when loading discs that they are correctly aligned and located in the rack

Failure to do so will result in mis-clamping

LOADING THE DISC'S

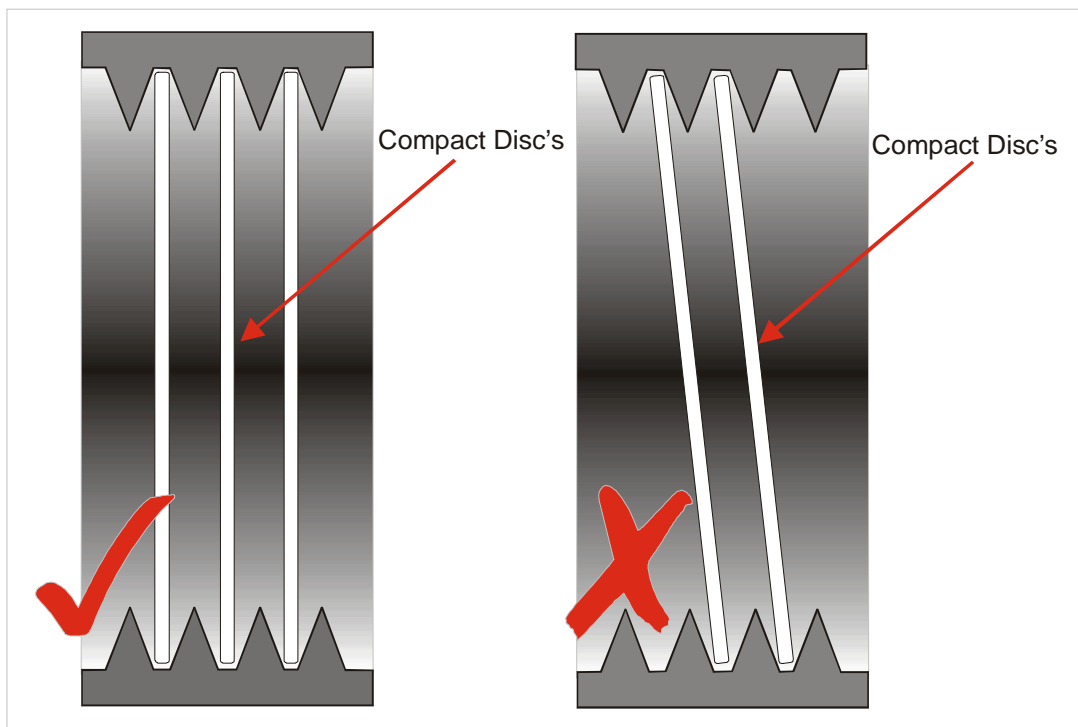

5. IMPORTANT NOTES

5.1 COMPACT DISC CARE

The disc is read from the surface on the reverse of the printed label side. The compact disc is fairly resistant to minor scratches and small amounts of dirt, but it is best to be careful not to scratch the signal surface and to keep it clean - free from dust, dirt and fingerprints.

Disc Cleaning

If the signal surface becomes dirty, always use the following cleaning instructions:-

When cleaning, use a soft cloth. Wipe the cloth from the centre of the disc to the edge of the disc until the complete signal surface is clean. **Do not** clean the disc in a circular motion as this can corrupt large amounts of information.

1. Fingerprints: Slightly rub the surface with a soft cloth.
2. Dust or Dirt: Blow lightly on the disc and wipe the dirty area with a soft cloth or clean the dirty area with a damp cloth and then wipe dry.
3. Grease or oil: Clean with a soft cloth dampened with ethyl alcohol, then wipe dry.

N.B. Conventional liquids and sprays used to clean records may damage the surface of the disc. Use of such cleaner is not recommended.

In addition, do not expose the disc to direct sunlight, heat or humidity for prolonged periods.

Ensure both sides of the compact disc are damage free. It is important to note that damage to picture side as well as the read side of the disc can result in corrupt data.

5.2 LOCKS

Some machines are fitted with two locks and require two keys to be used simultaneously.

5.3 MAKING A SELECTION

Five numbers need to be entered via the keyboard to make one selection.

Each disc location is identified by a three digit number i.e. 100 to 129/159/179. Depending on which Machine you have.

Example: Ensure the Machine is in credit.
To select a disc in location 145 enter the three digit number which identifies that disc, i.e. 145.
Having entered the disc number you now need to enter a two digit number for the track you wish to play from that disc. The track number must be in the range 1 to 30.

5.4 BUBBLE TUBES

These are fitted on certain styles of Jukeboxes. If there is any breakage resulting in skin contact (or eye) you should flush the area immediately with water (cold preferred).

For full material and safety specification refer to the data sheets in the centre supplement.

6. MK6 MONO SOUND SYSTEM

6.1 WARNINGS

Sound Leisure MK6 amplifier is not suitable for connection to a 100V line system.

6.2 MK6 PRE-AMPLIFIER

INPUTS Three 5-pin 180 ° Din sockets.

Input 1 CD (Line Input)

This input has priority and auto-fade control over input 2

The two stereo inputs are first combined into one mono signal before being split into two channels each with pre-set gain, bass and treble controls.

Input 2 Auxiliary (Aux Line Input)

Note! The base and treble controls for Input 1 are also used for this Input.

Auto-fade-in of this input occurs approximately 45 seconds after last track on CD input has finished.

This time length can be altered, by changing the value of capacitor C 11 on amplifier.

Input 3 Microphone (Mic)

The Mic input has the highest priority with auto-fade control over inputs 1 and 2. The Mic channel also incorporates pre-set gain, bass and treble controls.

N.B. Line Input Level assumed to be: 0.5V to 1V peak to peak. (Ideal = 0.75v.)

Also: the microphone should be a low impedance type (600Ω).

VOLUME CONTROLS

Independent control of each channel is possible via a 2 x 22kΩ (log) slider remote volume control (R.V.C.).

The RVC circuit is of the d.c. type and may be run over long distances without the use of screened cable.

6.3 MK6 POWER AMPLIFIER

Frequency Range 15Hz to 20kHz \pm 1dB

Load Impedance 4 Ω minimum (4 Ω optimum)

Power Output 60W per channel, r.m.s. into 4 Ω

The power output stage is short circuit protected.

6.4 MK6 SLAVE OUTPUT

The slave output is taken from pin, T3, on the pre-amplifier board. The signal ground for the slave amplifier can be picked up on the MK6 amplifier chassis. The slave output signal is controlled by the potentiometer, VR12, on the pre-amplifier board.

The slave output voltage is in the range: 600mV to 3V peak-to-peak.

N.B. When fitting a Sound Leisure slave amplifier it is necessary to upgrade the amplifier power supply fuses from 3.15A to 4A. Slow Blow. These fuses are located on the main SLE 1000 board labelled F2.

6.5 KARAOKE

The facility of Karaoke can be accomplished by lifting one end of resistor R71 on the MK6 pre-amplifier top board.

This disables the voice over function of the microphone.

Note: Connection T4 is not used.

FIG 6.6 MK6 CONTROLS

EXTERNAL VOLUME CONTROL CONNECTIONS VIA MAIN M.P.U.

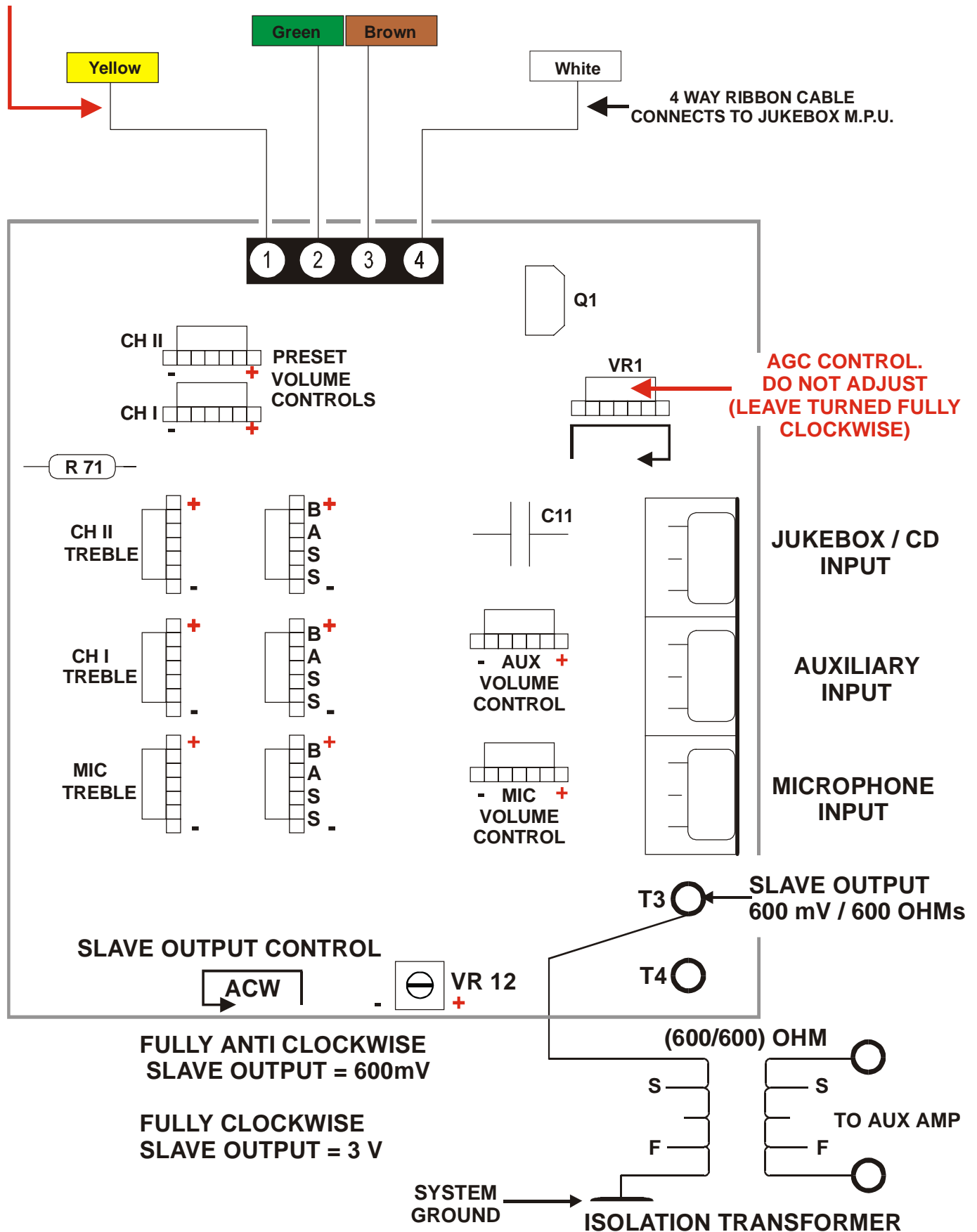
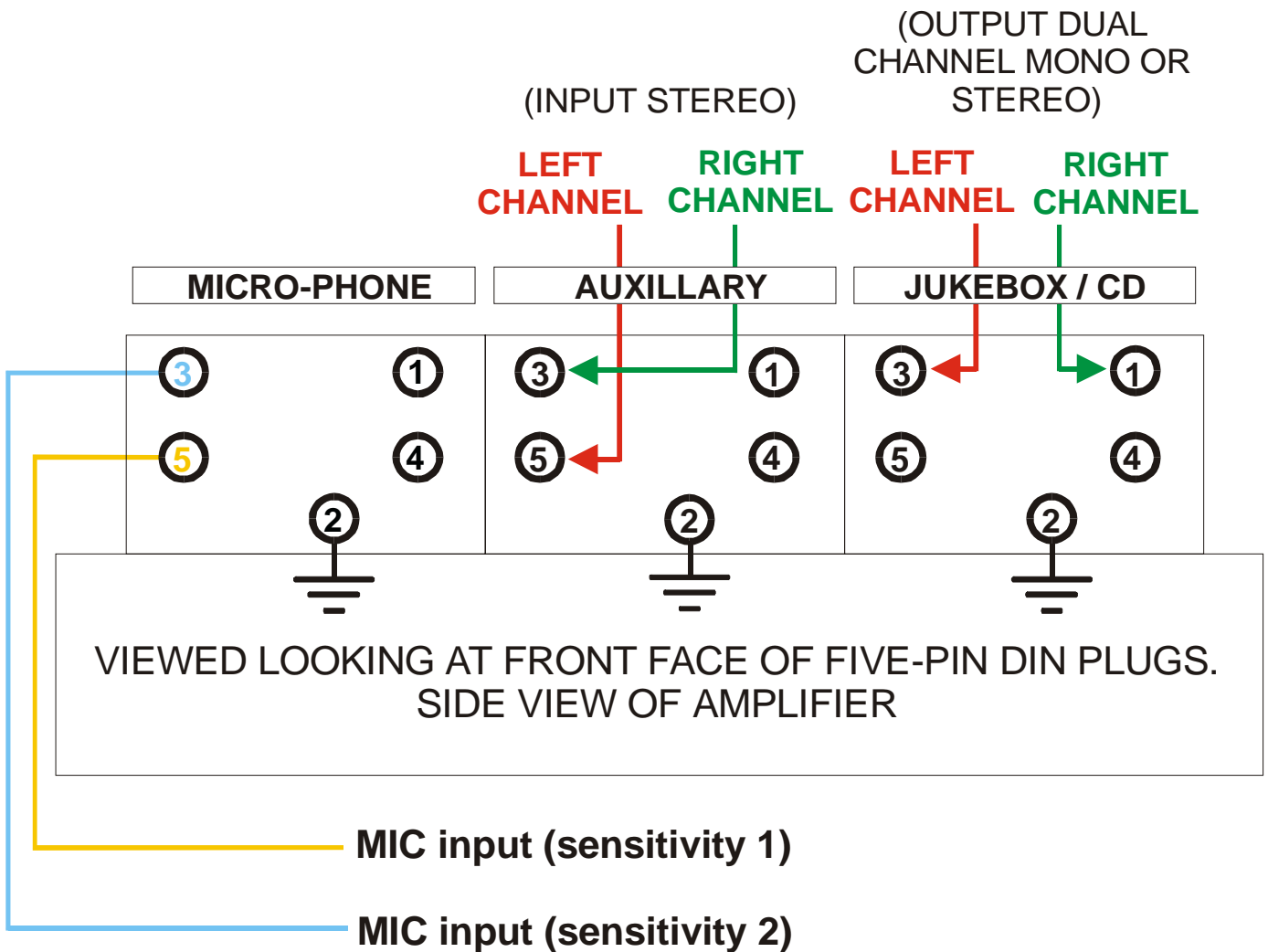

FIG 6.7 MK6 INPUT CONNECTIONS



7. MK7 STEREO/MONO SOUND SYSTEM

INPUTS Three 5-pin 180 ° Din sockets.

Input 1 CD (Line Input)

Stereo input with priority and auto-fade control over input 2.

Each channel has pre-set gain, base and treble controls.

In addition the stereo channels can be combined to form two, independent, mono channels.

Input 2 Auxiliary (Aux Line Input)

Auto-fade-in of this input occurs approximately 60 seconds after last track on CD input has finished.

Note! The base and treble controls used for Input 1 are also used for this Input.

Input 3 Microphone (Mic)

The Mic input has the highest priority with auto fade control over inputs 1 and 2. The mic channel also incorporates pre-set gain, bass and treble controls.

N.B. Line input level is assumed to be 0.5V to 1V peak-to-peak. (Ideal 0.7v.)
Also: the microphone should be a low impedance type (600Ω).

LEDS

There are three LED's on the pre-amplifier board. These are denoted L1, L2 and L3.

When the machine is first powered up, L1 will light for 10 seconds before proceeding to flash. This indicates that the PIC 16C84 micro-controller is working correctly.

When an audio signal is detected at the CD input, L2 will illuminate. This shows that an audio channel has opened and music should, therefore, be heard.

If a microphone input occurs, L2 will turn off and the music will fade out. As soon as microphone input ceases, L2 will turn on again and the CD audio signal will fade back in.

Operation of the auxiliary channel is indicated by L3 turning on. This can only occur when a signal is present at the auxiliary input and no CD input has occurred during the previous 60 seconds.

VOLUME CONTROLS

Independent control of each channel is possible via a 2 x 22 kΩ (log) slider remote volume control (R.V.C.).

The RVC circuit is of the d.c. type and may be run over long distances without the use of screened cable.

7.1 MK7 PRE-AMPLIFIER SET-UP

Set stereo/mono link, LK1, to: **M** for mono (normal pub installation).
ST for stereo, if required.

Leave link LK2 in the position shown on the pre-amplifier component layout diagram. (See page 19)

Set 8-way dil switches, SW1, to:

1 .. ON	5 .. OFF
2 .. ON	6 .. OFF
3 .. ON	7 .. ON
4 .. ON	8 .. ON

The function of the various potentiometers and their initial settings are shown in the following table:

CD			
CONTROL	CHANNEL 1	CHANNEL 2	DEFAULTS
Master Volume	VR1	VR2	Centre
Slave Volume	VR3	VR4	Centre
Mid Range	VR5	VR6	Centre
Treble	VR7	VR8	Manual Adjust
Bass	VR9	VR10	Manual Adjust

	AUXILLIARY	MICROPHONE	
Volume	VR11	VR12	Centre
Treble	VR7 & VR8	VR13	Manual Adjust
Bass	VR9 & VR10	VR14	Manual Adjust

7.2 MK7 SLAVE OUTPUT

The slave outputs are available at connector CON5 as follows:

- Pin 1 = Mute Output
- Pin 2 = Mic Signal Output
- Pin 3 = Channel 1 Music Signal Output
- Pin 4 = 0V Earth
- Pin 5 = Channel 2 Music Signal Output

Connection to these outputs should be done with a four-core screened cable and terminated at CON1 on MK7 slave amplifier input. CON1 is a 5-pin 180° DIN socket with the following pin-out:

- Pin 1 = Channel 2 Music Signal Input
- Pin 2 = 0V Earth
- Pin 3 = Channel 1 Music Signal Input
- Pin 4 = Mute Input
- Pin 5 = Mic Signal Input

7.3 MK7 POWER AMPLIFIER

Frequency Range: 15Hz to 20kHz \pm 1 dB.

Load impedance: 4 Ω minimum. (4 Ω Optimum)

Power output: 150W per channel, r.m.s., into 4 Ω .

FIG 7.4A MK7 CONTROLS

REMOTE 1 = Music override
 SWITCH 2 = 0v. Earth
 INPUTS 3 = Autofade override

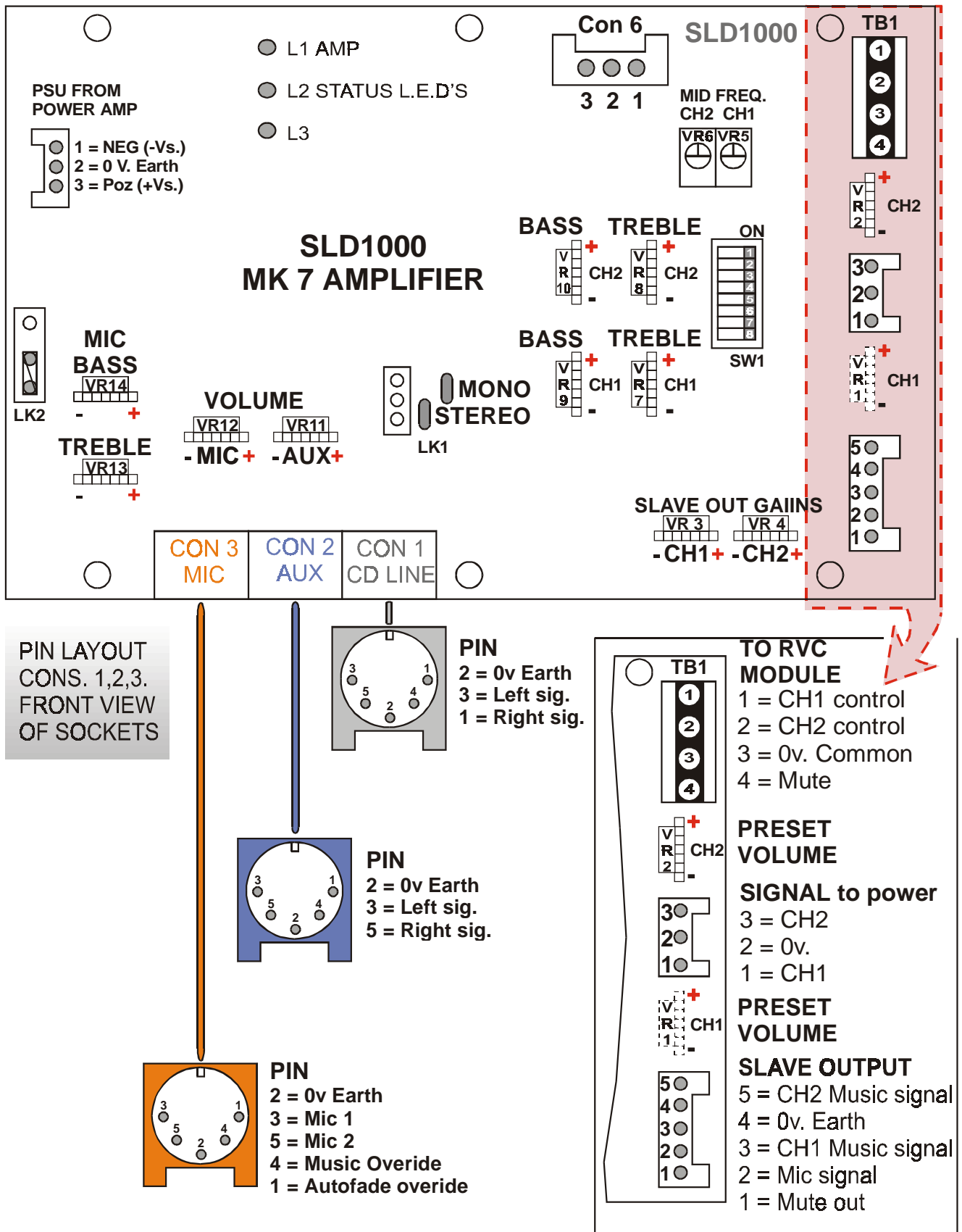
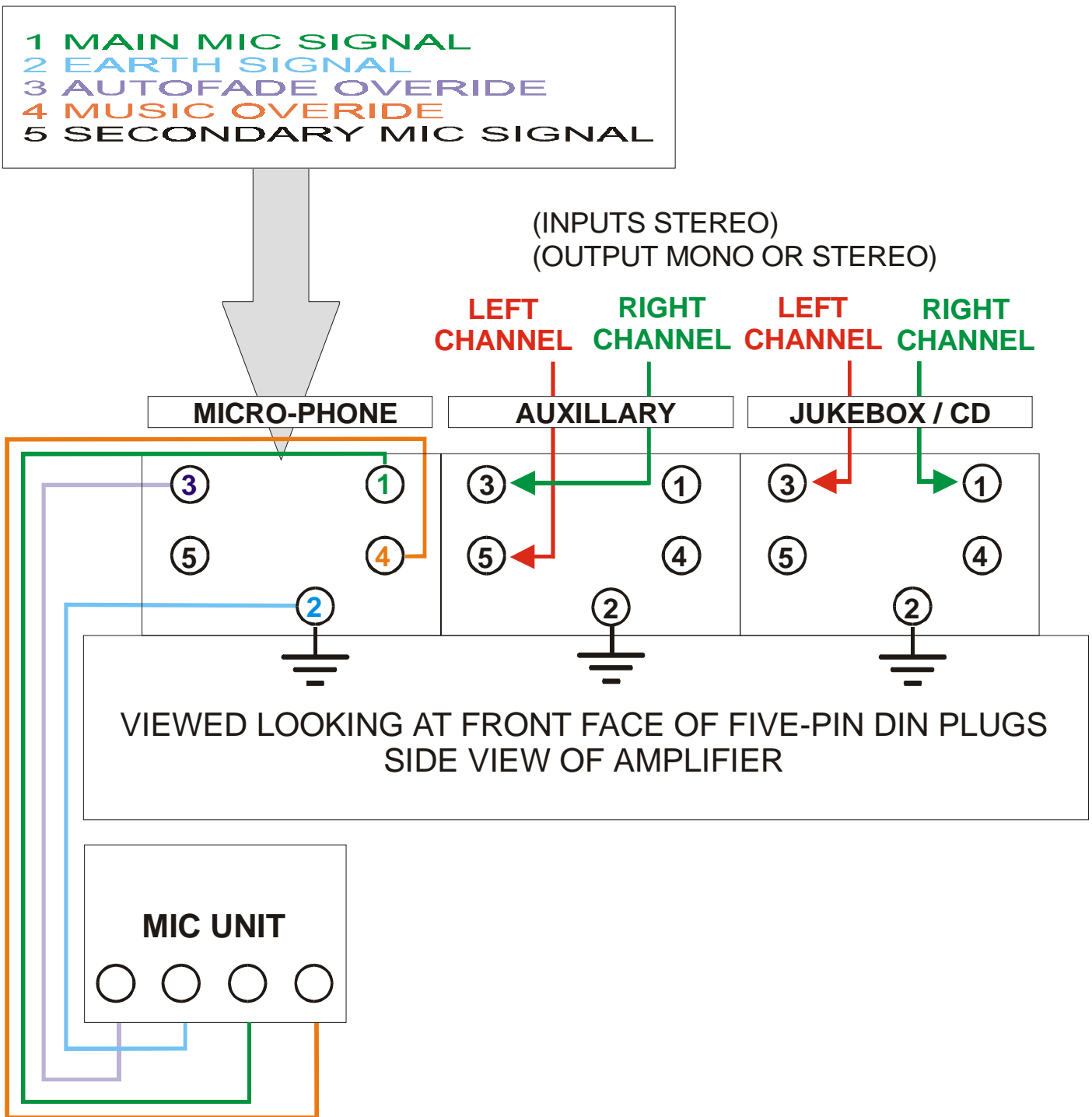

FIG 7.4B Mk7 INPUT CONNECTIONS



8. SPEAKER WIRING

The optimum load impedance for Sound Leisure amplifiers is 4Ω and should be regarded as a minimum value - do not go below.

The following diagrams depict various parallel/serial combinations of 8Ω speakers and the resulting load impedance.

8 OHMS

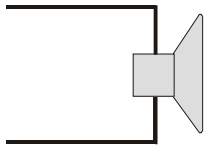

4 OHMS

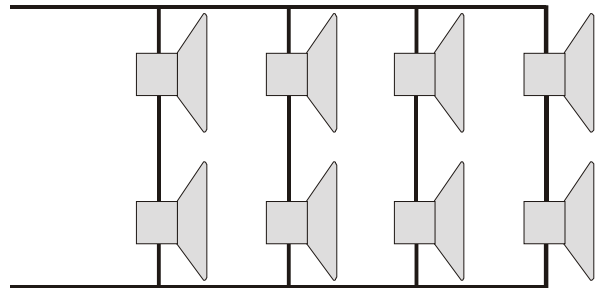

4 OHMS

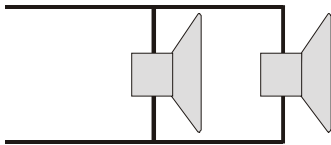

5.33 OHMS

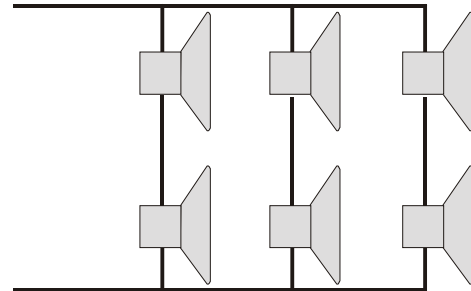

8 OHMS

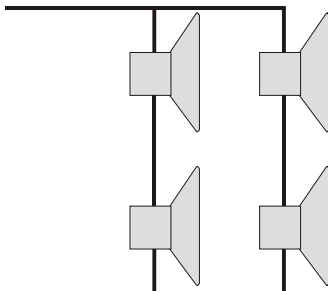

9. GMT/BST CLOCK ADJUSTMENT

A switch is provided on the BGM Interface SLE1014 to switch between GMT/BST.

10. BACKGROUND MUSIC (BGM)

See SLE1014 BGM Interface (F.G.M.= Forground music) Block Diagram in supplement.

BGM INTERFACE EXPLANATION

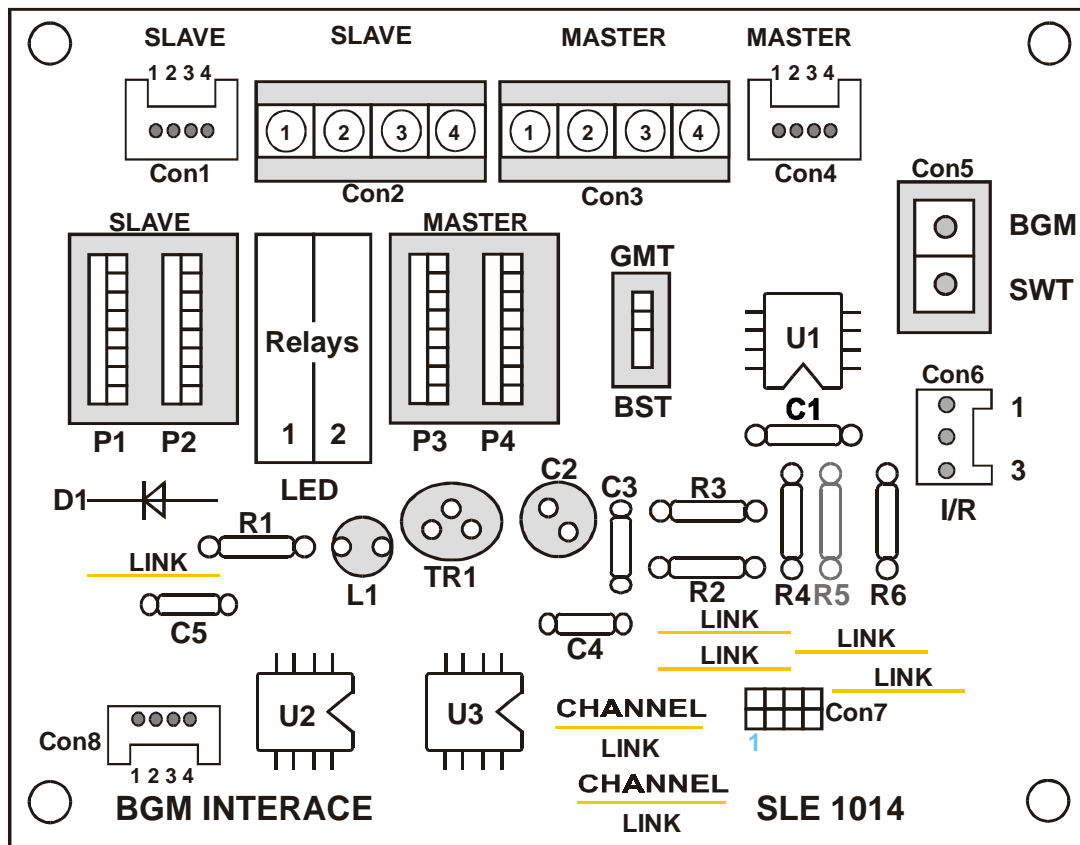

This BGM Interface Board allows for different levels of volume between BGM and FGM.

When FGM is playing the volume is set through the standard slider RVC's which are connected to this board and whose signals pass through this to the SLE1000 MPU and then to the amplifier.

When BGM is playing, the relay is energised and connects Potentiometers P1-P4 through to the amplifier(s) via SLE1000 MPU which allows settings of the BGM volumes.

Also provided on this board is a BGM input, to which a simple ON/OFF switch can be connected to allow the BGM to be turned ON and OFF remotely.

(Constant B.G.M.)

A BST/GMT switch is provided to alter the clock between BST/GMT. (Sect. 9)

Finally, a 3-way stocko connector Con 6 is provided so that an Infra Red receiver can be connected to provide future compatibility with Sound Leisure's Infra Red Remote Control.

Note:- DIL Switch 3 should be ON on SLE1000 Board to enable the remote BGM switch and BST/GMT switch.

NB. The SLE 1014 board can not provide for Infra Red Remote control and BGM facility together.

10.1 HOW IT WORKS - BGM

A table of the last 50 BGM discs/tracks played is kept in memory.

At **power on** the table is cleared. Each BGM Disc/Track is then added to the table. At the end of the table the pointer wraps round then overwrites at the beginning. The table is used to check that the same track does not play twice within 50 plays.

A table of the number of tracks for each disc is also kept. If there is no number of tracks for a disc then a track number is chosen from tracks 1 to 10. Once the number of tracks for a particular disc is known, then the random track chosen is that from 1 to the total number of tracks for that disc. This eliminates the wrap around on earlier systems which could cause (for example) track 1 and track 16 to play the same music track when the disc had a total of 15 tracks. This problem will still occur if the disc has less than 10 tracks.

It must be noted that because the memory stores the last 50 disc/tracks played, that setting the BGM band for a number of discs, of which the total number of tracks was 50 or less, then the machine would stop playing from the BGM band once all the tracks have been played. It is recommended that the total number of tracks available for BGM be greater than 50.

10.2 CONSTANT BGM

Constant BGM is achieved by programming menu 5 level 8 = 99

The discs selected for BGM will be that band previously programmed into: Menu Option 5, levels 3 and 4 (See section 12). Constant B.G.M. and random play is overridden by Paid Play.

10.3 TIMED BGM

Timed BGM is dealt with in Section 13, as a timed function.

11. DIL SWITCH SETTINGS

Note

The DIL switches are used to enable various functions, and to set various parameters.

11.1 WALLBOX SWITCHES

The following table shows the functions associated with each of the 8 DIL switches. In each case the function is enabled by turning the switch to the ON position and disabled by turning it to the OFF position.

DIL SWITCH	FUNCTION	COMMENTS
SW 1	Coin Lock-out	Used with Timer 1 - see Note 1
SW 2	Happy Hour	Used with Timer 5 - see Note 1
SW 3	Timed Free Credit	Used with Timer 6 - see Note 1
SW 4		Not used
SW 5	P-O-Polarity	Used in conjunction with DIL switch 7
SW 6	Retain Credits and Selections	Depends on software - see Note 2
SW 7	Programming Enable	Used with Operator Switch - see Note 3
SW 8	Permanent Free Credit	

NOTE DIL switch 7 is **always** used in conjunction with the Operator switch (door switch in Jukebox/Hideaway) whilst the programming is being carried out. See also Section 12 on programming.

11.2 HIDEAWAY/JUKEBOX

DIL SWITCH

1	ON	Set up/Transit switch <i>(Used to set up Mechanism and doubles as a Transit switch)</i>
2	OFF	Standard disc in highest location.
2	ON	Cleaning disc in highest location - will be played at power on to clean CD lens. No audio will be heard. Use lens cleaner Telstar (ALLSOP Model 5920) 6 Brush. Put lens cleaning disc in 129 for 30 select, 159 - 60 select and 179 for 80 select. <i>Use menu 5 level 8 = 99 for constant random play</i>
3	ON	Enables SLE 1014 board <i>(Used to say that the BGM board SLE1014 is present.)</i>
4	OFF	Credits, <i>(The Display shows the number of credits available to make selections.)</i>
4	ON	Show sync opto, count opto and number of plays <i>(Used during set up to show conditions of the sync. and count Opto's. Also shows total number of plays.)</i>
5	6	Dataret type <i>(Used to select the type of data retrieval system being used.)</i>
OFF	OFF	Simple dataret, fetch least played disc
ON	OFF	Psion
OFF	ON	BLMS Fender cartridge system.
ON	ON	BACTA Standard output. 7 ON Enter programming mode <i>(When on it enables the credit tables to be altered when in service mode)</i>
8	ON	Constant free play <i>(Constant free credit, no money is needed to allow selections to be made.)</i>

11.3 CREDIT BUTTON

For credits, open door and press Credit Button on SLE 1000 board
For amount of Credits required, ie. 3 Presses = 3 Credits.

The credits will only be shown several seconds after the door is closed.

The Credit Button is also used to perform a master reset. See section 2.1.
This does not affect the price of play or data held for popularity purposes.

11.4 SETUP KEYS

(used when DIL sw's 1 & 4 are turned **ON** and Machine is switched off and back on)

Key	1	Energise Phase 1 of horizontal stepper motor
	2	Energise Phase 2 of horizontal stepper motor
	3	Energise Phase 3 of horizontal stepper motor
	4	Energise Phase 4 of horizontal stepper motor
	5	Pick up arm to TOP (will not work at the player position)
	6	Pick up arm to BOTTOM
	7	Pick up arm to CD take OFF player position (will not work at the top opto position)
	8	Pick up arm to CD put ON player position (will not work at the bottom opto position)
	9	Pick up arm to RIGHT
	0	Pick up arm to LEFT
	C	Has two functions :- 1. Moves tower to Sync Position(disc 100) 2. When tower is over laser turn table and the bow arm is in CD play position. Key 'C' opens and closes clamp arm.

The Linear position of the tower, is shown on the top line of the display when DIL switch 4 is on and DIL sw 1 is on (*set up mode*)

Player position, for 30 play the count is 820, for 60 play the count is 760 and for 80 play the count is 1020. Use of buttons 1,2,3 or 4 will not alter the linear position readout, use 0 and 9 for this.

Self test program, press Eject (on SLE 1000) to run this program, see self test instructions.

12. PROGRAMMING - SERVICE MODE

P = PROGRAMME MENU

L = LEVEL

P	-		L	-
				-

CREDIT TABLES/MENU (DILSW 7 MUST BE ON)

12.1 PROGRAMME MENU STRUCTURE

MENU	1	2	3	4	5	6	7	8	9	0
MENU	PLAYS FOR PULSES IN MENU 2	NUMBER OF METER PULSES FOR COINS	MULTIPLE COIN ENTRY PLAYS	MULTIPLE COIN ENTRY COINS	SYSTEM DEFAULT SETTINGS PAGE 36/37	REAL TIME CLOCK PAGE 37	BGM TIMERS PAGE 37	DISC AND TRACK LOCKOUT NUMBERS	DISC AND TRACK LOCKOUT NUMBERS	
1	0	1(10p)	1	3(30p)	No. OF PLAY DISCS	Sec's	START HOURS T1	DISC A	DISC E	EPROM VERSION
2	0	2(20p)	0	0	TRACKS PLAYED PER DISC	Mins	START Mins T1	TRACK A	TRACK E	FREE CREDITS
3	2	5(50p)	0	0	START BGM BAND	Hours	STOP HOURS T1	DISC B	DISC F	NUMBER OF VIDEO DISCS
4	5	10(£1)	0	0	FINISH BGM BAND	Day	STOP Mins T1	TRACK B	TRACK F	1=VIDEO 2X.P.O.P
5	11	20(£2)	0	0	RETAIN SCROLL	Date	START HOURS T2	DISC C	DISC G	1st VIDEO TRACK NUMBER
6	0	0	0	0	DAYS T1 P. 37	Month	START Mins T2	TRACK C	TRACK G	COUNTRY P.O.P
7	0	0	0	0	DAYS T2 P. 37	Year	STOP HOURS T2	DISC D	DISC H	
8	0	0	0	0	RANDOM PLAY (Mins)		STOP Mins T2	TRACK D	TRACK H	

T1 = Timer 1

T2 = Timer 2

Menu 0 Level 1 Eprom version

Menu 0 Level 2 Number of times free credit

Menu 0 Level 3 Number of video discs *

Menu 0 Level 4 Set at 1 for double video price of play

Menu 0 Level 5 Lowest video starting track

Menu 0 Level 6 Country for scrolling price of play. 0 = UK, 1 = Spain

UK displays...n PRICE FOR X PENCE, Spain displays...n PLAYS FOR X PTS

*Note The band starts at 100. Therefore if you have 25 video discs your selections run from 100 to 124 the remaining selections will be audio

12.2 STANDARD PRICE OF PLAY TABLE

The standard price of play (PoP) table resides in menu's 1 to 4 as shown below.

	SINGLE COIN ENTRY		MULTI- COIN ENTRY	
	Plays	Coins	Plays	Coins
Level 1				
Level 2				
Level 3				
Level 4				
Level 5				
Level 6				
Level 7				
Level 8				
	Menu 1	Menu 2	Menu 3	Menu 4

Menu's 1 and 2 are closely related as are Menu's 3 and 4.
 In addition, the number of plays at each level in the play menu relate exactly to the value in the corresponding level in the coin menu.
 Now, suppose we wish to have price of play not covered by single coin entries, say, 30p. The corresponding value in 10p units would be 3 and this value would be entered into menu 4, in ascending order of value.

N.B. Those values which require multiple coin entries will be known as: intermediate values. Also, any unused menu levels should be zeroed.

The example given below should serve to clarify the general procedure for establishing a table of values.

Lets assume we wish to enter a new pricing programme for the following:

Price of Play - 1 Play = 50p, 3 Plays = £1, 7 Plays = £2, 12 Plays = £3

	SINGLE COIN ENTRY		MULTI- COIN ENTRY	
	Plays	Coins	Plays	Coins
Level 1	0	1	12	30
Level 2	0	2		
Level 3	1	5		
Level 4	3	10		
Level 5	7	20		
Level 6				
Level 7				
Level 8				
	Menu 1	Menu 2	Menu 3	Menu 4

12.3 DEFAULT SETTINGS

Menu 1 is the play table

	LEVEL	PLAYS
10p	1	0
20p	2	0
50p (NEW)	3	2 (2 plays for 50p)
£1	4	5 (5 plays for £1)
£2	5	11 (11 plays for £2)
	6	0
	7	0
	8	0

Menu 2 is the Standard Credit Table (Meter Pulses)

	LEVEL	PULSES
10p	1	1
20p	2	2
50p (NEW)	3	5
£1	4	10
£2	5	20
	6	0
	7	0
	8	0

Menu 3 is Intermediate Play Table

	LEVEL	PLAYS
	1	1 (1 Play)
	2	0
	3	0
	4	0
	5	0
	6	0
	7	0
	8	0

Menu 4 is Intermediate Credit Table

LEVEL	CREDIT
1	3 (30p)
2	0
3	0
4	0
5	0
6	0
7	0
8	0

Menu 5 Disc Table (Factory Setting)

LEVEL	
1	? 30/60/80 Discs (Number of Discs)
2	3 Consecutive Tracks (Tracks in a Row)
3	(1) 25/50/70 Minimum BGM Disc
4	(1) 29/59/79 Maximum BGM Disc
5	Retain / Scroll
6	Days 1 (0) Days for Timer 1. <i>See page 36-7</i>
7	Days 2 (0) Days for Timer 2. <i>See page 36-7</i>
8	RND (0) Random Play in Minutes

12.4.1. Entering Programming Mode

Open the door

Disc ejects, pick up arm moves to centre

Turn DILSW 7 'ON' on SLE 1000

Display shows

P	-		L	-
				-

12.4.2. SELECTING A PROGRAM MENU

When the display shows P--L-- , any menu may be entered. This is achieved by pressing the required program menu number (1-9, 0).

For example: if program menu 2 is selected and level 1 of that program menu contained the value 5 then the display will go through the following sequence:

P	-		L	-
				-

P	2		L	1
				5

DATA LOCATION

12.4.3 SELECTING A LEVEL

Once in a particular program menu, a level can be selected simply by pressing the required level number (1-8).

12.4.4. EDITING DATA IN LEVEL

Assuming the correct level of the required program menu has been located, then new values are entered between two presses of the 'C' key.

e.g. Press 'C' , enter value then Press 'C'.

The first "C" clears the previous information. The second Press of the "C" Key locks in the new information.

12.4.5. EXITING A MENU

Exiting a menu is accomplished by pressing the '0' key which will result in the display reverting to the point at which programming mode had been entered, i.e. showing P--L--. At this point another program menu can be entered if required.

12.4.6. EXITING PROGRAMME MODE

Once programming has finished it will be necessary to return to normal operation. This is accomplished by reversing the entry procedure.

1. Turn DIL switch 7 OFF on SLE1000.
2. CLOSE DOOR.

The following, full, example should serve to reinforce the above procedure.

12.4.7. EXAMPLE

For the purpose of this example it will be assumed that we wish to change program menu 1, levels 3 and 4, from the settings of: 2 and 5, to: 1 and 3, respectively.

1. OPEN DOOR
2. Turn DIL switch 7, ON, at the Juke/Wallbox at which the programming is to be done.

P	-		L	-
				-

EXAMPLE (Cont)

3. The required Program menu number 1, is now entered. It will then clear before displaying the contents of level 1 (0).

P	-		L	-
				-

P	1		L	1
				0

The display now shows the level number, 1, on the top display followed by the current value, 0, in the level data digits below. This value does not need changing and another level needs to be entered.

This is done by simply entering the required level number. In this case 3 would be the logical choice although levels can be edited in any order.

4. Press '3' key. The display now shows:

P	1		L	3
				2

The new value in level 3 is entered between two presses of the 'C' key.
e.g. Press 'C' enter value then Press 'C'.

5. Press 'C' key. The display will show:

P	1		L	3

indicating that the value in level 3 has been cleared so as to allow a new entry.

6. Enter new value, 1, by pressing '1' key. The display should change to:

P	1		L	3
				1

EXAMPLE (Cont)

7. Press 'C' key again. This 'locks-in' the new value.

All that now remains to be done is to re-program level 4.
This is accomplished in the same way.

8. Enter number 4, Display shows:

P	1		L	4
				5

9. The required value in level 4 is 3 and is entered between two presses of the cancel, 'C', key.

10. Press the 'C' key. The display now shows.

P	1		L	4

11. Enter the new value, 3, by pressing the '3' key. The display should show the sequence:

P	1		L	4
				3

12. The new value is now 'locked-in' by another press of the 'C' key. Levels 3 and 4 are now re-programmed so all that remains is to exit.

13. To exit the program menu, press '0' key. The display should revert to showing :-

P	-		L	-
				-

14. TURN OFF DIL SWITCH 7.

15. CLOSE DOOR.

This completes the programming sequence with the display alternating between showing last played disc and track numbers.

12.5. MENU 5

Program menu 5 holds those values used to define the size and positioning of the two 'Disc Bands' and the maximum number of consecutive plays per disc. This program menu is illustrated below with its default or factory settings.

Program menu 5

	Option 5	
Level 1	60	FOR 60 PLAY MECHANISM
Level 2	3	DEFAULT
Level 3	50	FOR 60 PLAY MECHANISM
Level 4	59	FOR 60 PLAY MECHANISM
Level 5	Retain / Scroll	
Level 6	Days T1	
Level 7	Days T2	
Level 8	Random / min's	

Level 1 This value defines the maximum number of discs that are selectable from the keypad - sometimes referred to as the foreground music (FGM) disc band. It does this by disabling the keyboard for numbers greater-than or equal-to the number entered in this level.

For example: if the number entered was 35 this would not allow selections of 135 and above, i.e.. it will only allow selection of the first 35 discs, 100 to 134 inclusive.

Level 2 This level holds the maximum number of tracks allowed to be played from any disc consecutively.

12.6. EXPLANATION OF TRACKS IN A ROW

The system currently works by playing in selected order.

If the following selections are made (tracks in a row = 3)
100,01, 100,02, 100,03, 100,04, 100,05, 100,06, 100,07,
159,01 then they will be played in that order without returning the disc to the rack.

If however these selections are made and tracks in a row = 3
100,01, 159,01, 100,02, 100,03, 100,04, 100,05, 100,06, 100,07
then they will be played as below
100,01, 100,02, 100,03, 159,01, 100,04, 100,05, 100,06, 100,07.

Note that the selections are searched for up to 3 tracks from the disc

that is currently on the turntable.

Thus it can be said that the program will look for n tracks from the same disc except if the selections from the same disc have been made in order.

Levels 3/4 The value in level 3 relates to the start location for those discs chosen to be in the BGM disc band whilst the value in level 4 corresponds to the final location.

Again, the BGM disc band must be continuous with no gaps. However, unlike the FGM disc band which must begin at location 100, the B.G.M. band can be placed anywhere in the Rack.

NOTE: The disc band numbers are entered as two digit numbers. ie. Discs 150 and 159 are entered as 50 and 59 respectively.

Level 5 Retain/Scroll

- =0 No features
- +1 Scrolling Price of Play
- +2 Retention of Credits/Plays
- +4 To show Cr for Credits
- +8 MHG DATARET SYSTEM PSION
- +16 Changes Timer 2 from BGM to free credits, *see page 37*
- +32 Video relay

Example. If you require Scrolling Price of Play plus Retention of Credit ie. +1 and +2.....Level 5 must be set to +3

Level 6. Days Timer 1 **Level 7. Days Timer 2**

Day or days over which timers will operate.

days =0	none	days =0	none
=1	weekdays	=1	weekdays
=2	weekend	=2	weekend
=3	every day	=3	every day

For customised location requirements, individual days may be set. Starting with the number 3 then add any combination of the following for each day required.

+1 = Saturday, +2 = Friday, +4 = Thursday, +8 = Wednesday, +16 = Tuesday, +32 = Monday and +64 = Sunday.

eg. Thurs & Fri only = 3 + 4 + 2 = 9, **enter** a 9 for days.
Wed only = 3 + 8 = 11, **enter** the value 11
Sat & Sun = 3 + 1 + 64 = 68. Sun, Mon & Tues = 3+64+32+16=115

12.7 RANDOM PLAY

Level 8. RND = Random Play in Minutes

- 0 = No Random Play
- 1 - 98 = Number of Minutes
- 99 = Constant Random Play (BGM)

13. TIMED FUNCTIONS

Note.

There are two timers available to the users of 21st Century Systems. These are designated T1 (Timer 1) and T2 (Timer 2)

Changes to Timer 1 and Timer 2 can be made via the selection keypad. See programming (section 12)

N.B: Timed BGM is overridden by paid play.

THE RTC

Before the Timers can be used the Real Time Clock must be set correctly. The correct time is entered in Program Menu 6, Levels 1 - 7 using the selection keypad. See programming (section 12) Remember..... for the day. Sunday = 1, Monday = 2 etc. Saturday = 7.

THE TIMERS

BGM will be played during the times for which the Timers are set. Each timer has a Start Time (hours and minutes), and a Stop Time (hours and minutes), and also the days in which the time is valid.

Set the Timer(s) you wish to use. Start Hours, Start Mins, Stop Hours, Stop Mins. These are in Program Menu 7, Level 1 - 4 for Timer 1 and Level 5 - 8 for Timer 2.

Timer Days: The days for which the Timers are valid are entered in Program Menu 5, Level 6 for Timer 1 Days and Level 7 for Timer 2 Days.

The value entered is as follows:

- 0 = Never
- 1 = Weekdays (M,T,W,T,F)
- 2 = Weekends (S,S)
- 3 = Everyday (S,M,T,W,T,F,S)

For individual days see page 36

Timer 2 can also be used for timed free credit. Enter the times for which timed free credit is required. Add + 16 to the value in program menu 5 level 5 and the number of credits given each minute in program menu 0 level 2. Don't forget to set the days. (P5 L7)

14. TRACK LOCKOUT

The 21st Century Systems allow up to 8 tracks from the same or different discs to be locked out from the main SLE1000 Board so that they cannot be selected (does not apply to early wallboxes).

The Disc's and Track's are entered in Program Menu's 8 and 9, Levels 1 - 8.

The eight tracks are identified as A - H. Thus if disc 129, Track 09 was not required to be selected, because of bad language for instance, then 29 would be entered in Program Menu 8, Level 1 (Disc A) and 09 would be entered in Level 2 (Track A).

By entering other Discs and Tracks in Levels B - H (see Program Menu Structure P27), then up to 8 Tracks can be locked out.

You must remember to reset the values entered back to Zero for Disc and Zero for Track when offending Disc is removed from the machine.

15. INFRA RED REMOTE CONTROL (Home unit optional extra)

Use keys 0-9 to make your selections

EG. 100 02 for Disc 100 Track 02

Press CANCEL when making a selection to correct a mistake.

Press EJECT TRACK whilst a track is playing, to eject that track.

Press EJECT DISC to eject the whole disc.
Use VOLUME + - to select the required volume setting.

To select the whole disc, enter track number 00.

Whilst searching for the disc the display will show -0 for the track.

To eject selected whole disc, press eject disc once.

A = Turns BGM on, B = Turns BGM off.

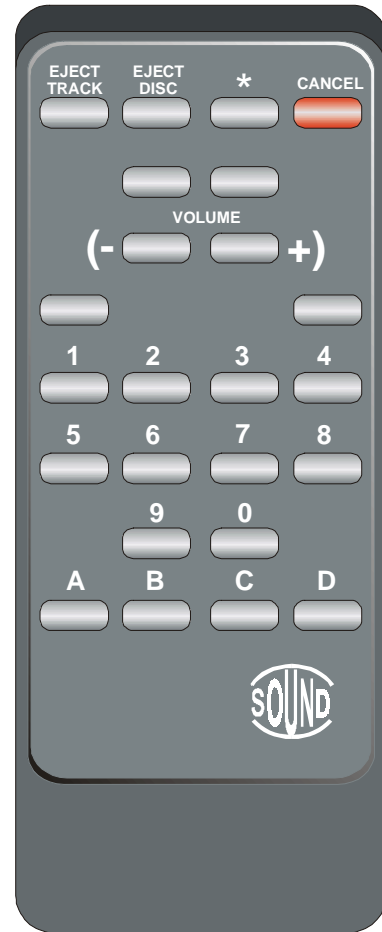

The Infra Red Remote Control requires an SLE1014 interface Board.

Please refer to diagram 'INFRA RED' in supplement section.

1. Connect up the I/R sensor (D) to Con.6 on SLE1014
2. Connect Con.7 on SLE1014 to Con.16 on SLE1000 via 8 way lead(A)
3. Connect Con.8 on SLE1014 to Con.13 on SLE1000 via 4 way lead(B)
4. Connect the floating earth wire (G) from SLE1014 to earth terminal in back of cabinet located alongside AC fuses.
5. The remote slider volume control is no longer required.

Note:- The SLE1014 board is a dual function board. ie BGM or Infra Red. This board can be used for BGM Volume or Infra Red remote control 'but not both' together.

16. DISC ERROR LOG.

Ensure Dil switches 1 and 7 are turned 'OFF' on SLE1000

When opening the door the display will show disc 100.

If this disc was logged as faulty, the track display will flash E00.

If the disc was OK, the track display will flash 00.

Press key 2 to move up the log to the next faulty disc.

Press key 1 to move down the log.

Press key 5 to clear the error log, after its been viewed and noted.

17. PLAY MECHANISM SET-UP " 21st CENTURY "

FIG 17.1 DISPLAY FORMAT IN TEST MODE

The digits on the SLE2056 display are numbered as shown below

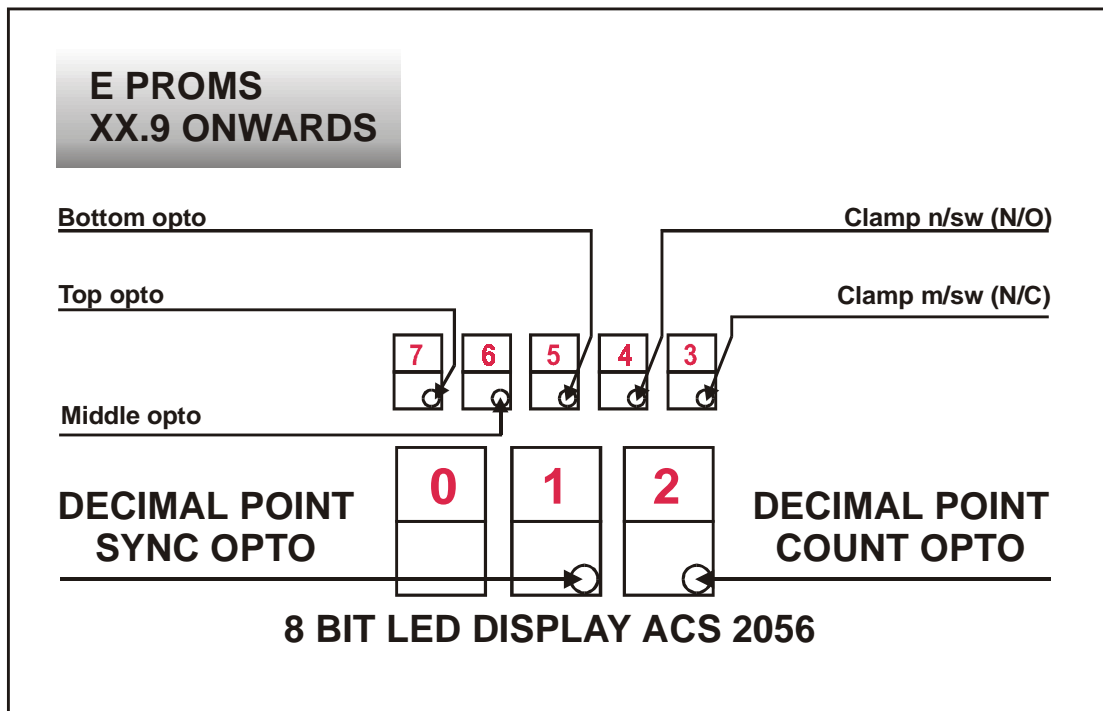

The decimal points of the top 5 digits indicate the condition of the opto's on the tower and the clamp microswitch contacts. The decimal points on the lower digits indicate the condition of the sync and count opto's. The top 5 digits show the linear position of the lift bow (pick up) arm.

<u>Opto's - tower</u>		dp = decimal point	
Digit 7	dp	on = top opto open	off = top opto blocked
Digit 6	dp	on = middle opto open	off = middle opto blocked
Digit 5	dp	on = bottom opto open	off = bottom opto blocked

Microswitch - CD clamp assembly

Digit 4 dp on = N/O contacts made off = N/O contacts open
Digit 3 dp on = N/C contacts made off = N/C contacts open
Clamp open = N/C contacts made and N/O contacts open
Clamp closed = N/C contacts open and N/O contacts closed

Count opto

Digit 2 dp on = count opto open off = count opto blocked

Sync opto

Digit 1 dp on = sync opto blocked off = sync opto open

Con't.

All settings are preset at Factory and should not require any adjustment unless fitting new parts, belt, motor or opto units.

17.2 CHECKING OF FACTORY SETTINGS

Pick up arm (Tower) assembly OPTO settings

Open the door and pull out door switch, select disc 100 and reject so that the pick up assembly is at rest in position 100.

Turn Machine OFF

Turn DIL switches 1 & 4 to 'ON' position.

Turn Machine back ON

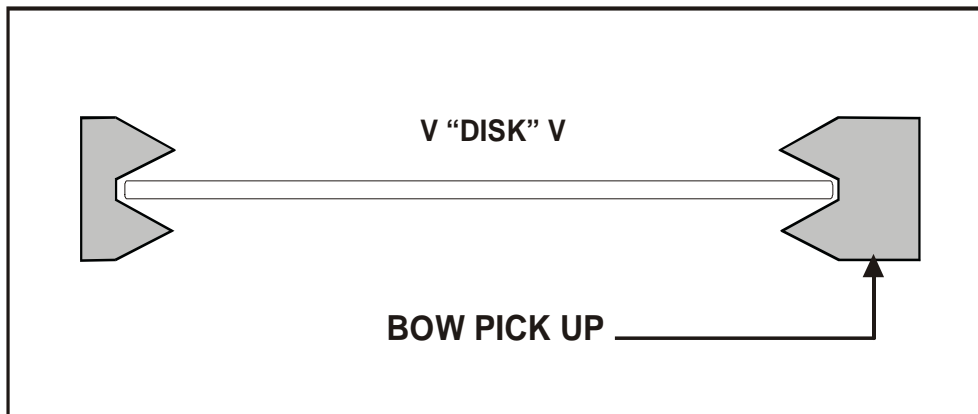

The two decimal points on the L.E.D. display should be on for Sync and Count. (see section 17.1)

Then press Key Switch 2.

The SYNC OPTO should be ON and the COUNT OPTO could be ON or OFF.

Press Key Switch 3. The SYNC Should be ON and the COUNT OPTO should go OFF.

Press Key Switch 4. SYNC OPTO---ON. COUNT OPTO---OFF.

Press Key Switch 1. SYNC OPTO---ON. COUNT OPTO---OFF.

Press Key Switch 2. SYNC OPTO---ON. COUNT OPTO---OFF.

Press Key Switch 3. SYNC OPTO---ON or OFF COUNT OPTO---OFF.

Press Key Switch 4. SYNC OPTO---ON or OFF COUNT OPTO---OFF.
Press Key Switch 1. SYNC OPTO---ON or OFF COUNT OPTO---OFF.
Press Key Switch 2. SYNC OPTO---**OFF**.COUNT OPTO---OFF.

REVERSE SEQUENCE

Press Key Switch 1. SYNC OPTO---ON or OFF COUNT OPTO---OFF.
Press Key Switch 4. SYNC OPTO---ON or OFF COUNT OPTO---OFF.
Press Key Switch 3. SYNC OPTO---ON or OFF COUNT OPTO---OFF.
Press Key Switch 2. SYNC OPTO---ON. COUNT OPTO---OFF.
Press Key Switch 1. SYNC OPTO---ON. COUNT OPTO---OFF.
Press Key Switch 4. SYNC OPTO---ON. COUNT OPTO---OFF.
Press Key Switch 3. SYNC OPTO---ON. COUNT OPTO---OFF.
Press Key Switch 2. The SYNC should be ON and the COUNT OPTO could come back ON .
Press Key Switch 1. Both should be ON.
Press Key Switch 4. SYNC OPTO should be ON.COUNT OPTO can be ON or OFF (Both OK)

CHECKING OF FACTORY SETTINGS cont.

Press Key Switch 3. (SYNC still ON) COUNT OPTO should be OFF
Press Key Switch 2. (SYNC still ON) COUNT OPTO should be OFF
Press Key Switch 1. (SYNC still ON) COUNT OPTO should be OFF
Press Key Switch 4. (SYNC still ON) COUNT OPTO should be OFF
Press Key Switch 3. (SYNC still ON) COUNT OPTO should be OFF
and pick up (Tower) assembly should be touching end stop.

Turn Machine OFF and turn DIL switches 1 & 4 to OFF position, then turn Machine back ON. Machine should return to normal operation.
(If not a "Master Reset" may be required.) See section 2.1

Con't.

17.3 RE-ALIGNMENT OF 21ST CENTURY MECHANISM

If any of the "Checks of Factory Settings" are not correct, or new components are fitted then the following steps should be followed

Turn Machine OFF and turn DIL switches 1 & 4 ON, then turn Machine back ON.

Position Tower to Disc position **130** for 60 play Mechanism, (**140** for 80 play and **129** for 30 play) by hand. Check that the Disc aligns with both Rack and Lift Bow.

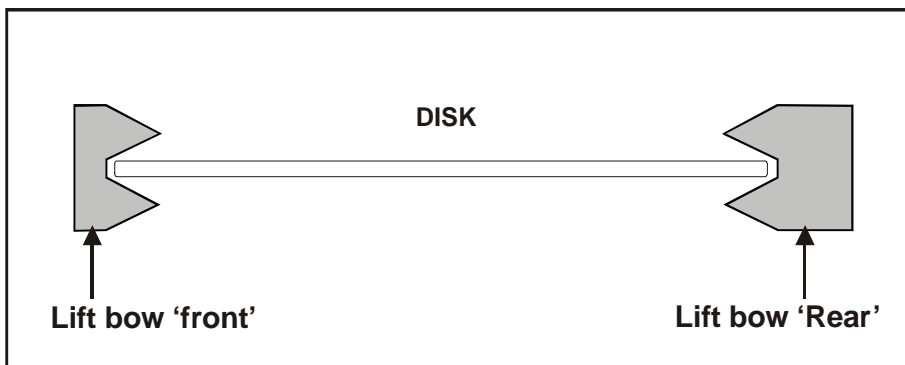

Press Key Switch 1 the Motor will move to Phase 1. If the Bow moves out of alignment, then release the lock screw (Pozi Drive) on Motor Pulley (toothed) Wheel, turn the pulley on the motor shaft, moving the Tower via the belt until the Bow aligns to the Disc. Retighten the screw and "check" by pressing Key 1, that the decimal point (count) is lit and the Bow, Disc and Rack are still aligned. *

If the decimal point (count) is not lit, then release the OPTO Wheel lock screw (Socket Drive) and turn until a slot aligns with the centre of the OPTO, lighting the decimal point (count), then lock the screw and check the other Phases (steps). *

Press Key Switch 2 count OPTO should still be ON

Press Key Switch 3 count OPTO should go OFF

Press Key Switch 2 count OPTO should come back ON

Press Key Switch 1 count OPTO should still be ON

Press Key Switch 4 count OPTO can be ON or OFF (both OK)

Press Key Switch 3 count OPTO should be OFF

WARNING. *The motor should only be energised for as long as necessary. Press cancel to de-energise any phase (steps).*

When all above "Checks" are correct.

Press Cancel, the Tower should return to position **100**, when the Tower comes to rest, check that the Bow, Disc and Rack are all in alignment and that both decimal points (Sync and Count) are lit.

Check the above by following the "Factory Setting Check" on page 41

* see sketch page 44

17.4 END STOP

When the Tower is at position **100**, the end stop should be 6 steps clear of the side of the Tower.

To reset, undo the Stop locking screw.

Press cancel, then Keys 4,3,2,1,4 and 3. Bring stop to the side of the Tower and retighten Stop locking screw.

Turn Machine OFF and turn DIL switches 1 & 4 to OFF position, then turn Machine back ON. Machine should return to normal operation. (If not a "Master Reset" may be required.) see section 2.1

17.5 TOWER OPTO SETTINGS. (See mech set up diagram on page 45)

Select a Disc.

Whilst playing switch Machine OFF and turn DIL switches 1 & 4 to ON position then turn machine back ON.

Press Key Switch 7, the Lift Bow should rise and make contact with the disc, but must not lift the Player.

If it lifts the Player, undo the two screws that secure the OPTO P.C.B. to the side of the Tower and slide P.C.B. down. (0.5 mm.)

If it does not contact the disc undo the screws and slide the P.C.B. up (0.5 mm.) do not grip the Disc, you should be able to turn the Disc when Key Switch 7 is pressed. Please note there are different sizes of Discs.

Press Key Switch 6, the Lift Bow should return to the bottom position.

If the gap of 0.5 mm between the carriage and the bottom stop is incorrect, the stop should be adjusted by releasing the locking screw situated in the side of the bottom stop (brass collar), then slide the stop up or down the guide rod and relock the screw.

Turn Machine OFF and turn DIL switches 1 & 4 to OFF position, then turn Machine back ON. Machine should return Disc to its original position in Rack. (If not a "Master Reset" may be required and the disc retrieved by hand.)

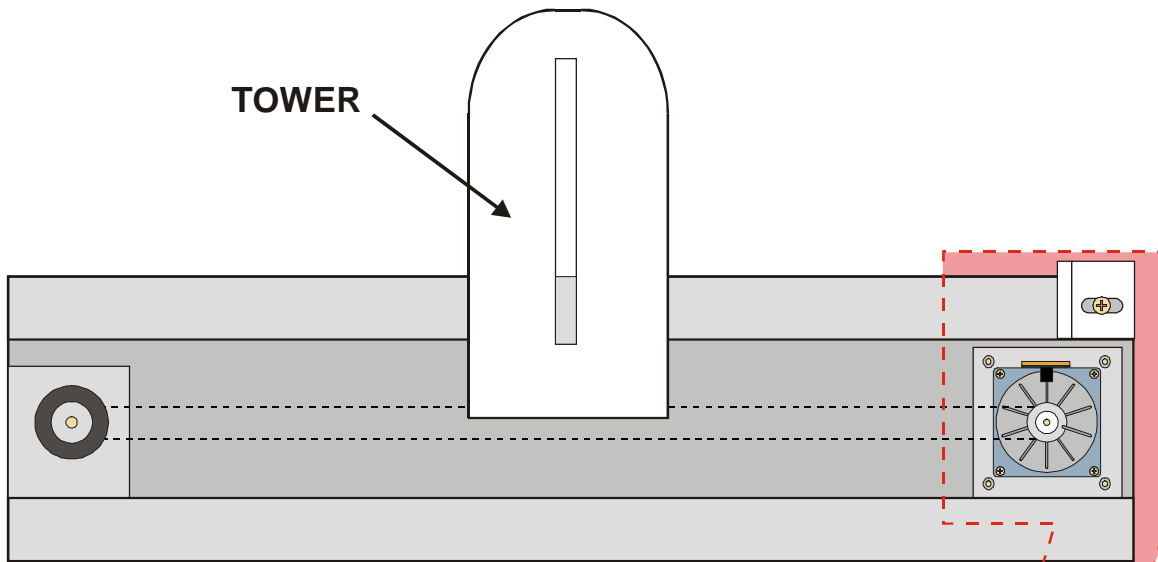

MECHANISM VIEWED FROM THE REAR

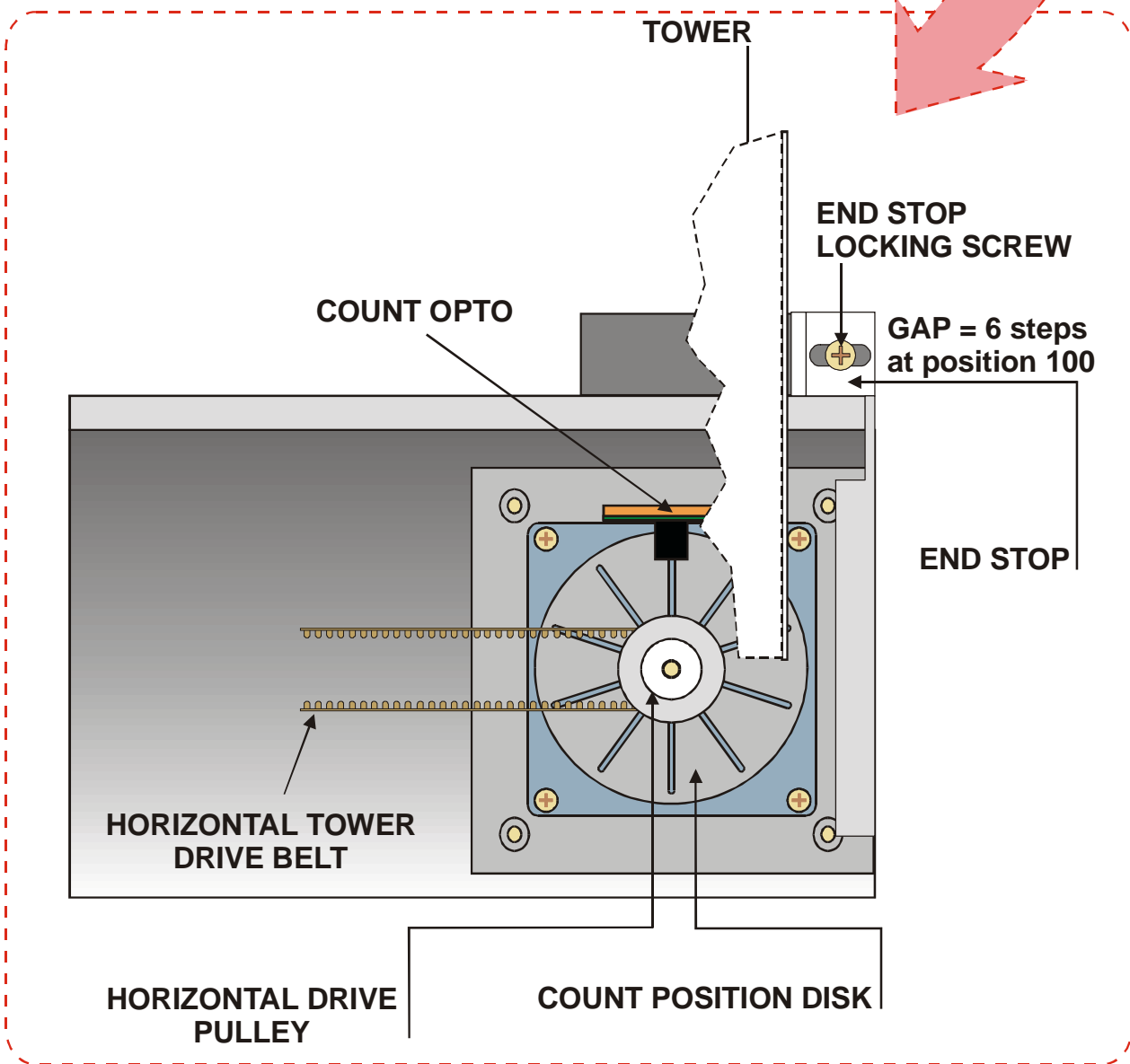

17.6 SELF TEST INSTRUCTIONS

After entering setup (dils w 1,4 on-switch on) pressing eject on SLE1000 Board will start a self test program - use this when there is no disc on the player and when a known good audio disc is at location 101. The test takes just over 1 minute to complete.

The sequence of testing is as follows:-

1. A display test shows 99999999 then 88888888 etc. until 00000000 with decimal points showing. (Check visually for any segment not lit)

The track displayed will be 00 now indicating no errors yet. During the test you must watch the display for any errors which occur.

2. ***Eprom Checksum Test*** - A test is performed on the Eprom to see if the checksum matches that when the Eprom was first installed - E01 (error 01) will be displayed if the test fails. this error will not stop the rest of the test (replace the Eprom if E01 is shown, follow this sequence turn off - change Eprom - turn off dils w 1 - turn on - 11 is displayed (new checksum) - turn off - dils w 1 on - turn on - perform test again).

If this was the only error found, the display would show E01 at the end. If another occurred afterwards E01 would be overwritten, but E01 would have been displayed for at least 2 seconds.

3. ***Ram Test*** - A non destructive test performed on the Ram E10 (error 10) will be displayed if the test fails. This error will not stop the rest of the test. (replace Ram if E10 shows, turn off - replace Ram - turn on - retest)
4. ***68hc 11 Ram Test*** - A non destructive test is performed on the 68hc 11 Ram. E11 (error 11) will be displayed if the test fails. This error will not stop the rest of the test. (replace 68hc 11 if E11 shows, turn off - replace 68hc11 - turn on - retest).
5. ***Credit Check*** - A check is performed on the credit table for any rogue values i.e. Any plays that have no matching credits. E40 (error 40) will be displayed if the test fails. This error will not stop the rest of the test. (check the credit tables if E40 shows and retest).

6. **Coin Mech** - A Byte in memory is checked to see if the last coin was rejected or got stuck. E50 (error 50) will be displayed if the test fails. This error will not stop the rest of the test.
(clear jam and check acceptance if E50 shows - when a coin is accepted the Byte in memory is cleared).
7. **Wallbox Ports** - Each Wallbox Port is directly check for short circuit
E81 will be displayed for Wallbox Port 1 short circuit
E82 will be displayed for Wallbox Port 2 short circuit
E83 will be displayed for Wallbox Port 3 short circuit
This error will not stop the rest of the test.
(clear short and retest if E8x shows)
8. **Keyboard Bit* Stuck Test** - Make sure no keys are pressed.
E84 will be displayed if IC u6 (on SLE1000) pins 1,2,3 or 4 are low and no keys are pressed. (could be faulty input of Keyswitch Short Circuit if E84 shows).
9. **Coin Input Bit* Stuck Test(*Bit = Information to M.P.U)**
E85 will be displayed if IC u6 (on SLE1000) pins 5,6,7 or 9 are low (all normally high when not accepting coins)
(could be faulty input or coinmech if E85 shows).
10. **Mechanism Test** - The Mechanism should perform the following operations (listed alongside are any error codes).

Any error conditions encountered will stop the test, except for E60 (can't play track 1 of disc 101). If a Syncing error is found, the mech. may continue to keep trying to find Sync-Check Mechanism Setup. Remember any error which say faulty Opto/Switch can be checked by looking at the appropriate decimal points on the display.

Start of Test	
Bow to bottom	E71 Bottom Opto not found (faulty opto/jam)(or E86/E87)
Tower to Sync position	Please check visually that position 100 is reached E72 Sync not found (faulty Opto/Jam/Wrong Setup fuse 3 could be blown if tower doesn't move) E73 count not found at Sync position (faulty count Opto/Jam/Incorrect mechanism setup)
Tower to Park Position	E74 Sync (Sync still found at wrong position faulty Opto/Jam/Wrong Setup) E75 count not found at position (faulty count Opto/Jam/Incorrect Mechanism Setup)
Bow up to Middle	E76 Middle Opto not found on way up (or E88) (Faulty Opto/Jam)
Bow to Top	E77 Top Opto not found (faulty Opto/Jam)
Bow down to Middle	E78 Middle Opto not found on way down
Bow to Bottom	E71
Close Clamp	E79 Clamp not closed (faulty Switch/Input/Motor/Op)
Open Clamp	E70 Clamp not open (faulty Switch/Input/Motor/Op)
Tower to last disc	E74/E75

Tower to Disc 101	E74/E75
Bow to top	E77
Tower to Transfer Pos	E74/E75
Bow down to middle	E78
Tower to actual player	E74/E75
Close clamp	E79
Bow to bottom	E71
Play Track 01	E60 can't play track 01 (no/bad disc,cdm12 psu?,clean lens/)
Bow up to middle	E76 (must not be video disc)
Open Clamp	E70
Tower to Transfer Pos	E74/E75
Bow to top	E77
Tower to 101	E74/E75
Bow to bottom	E71
End of Test	

Park position is the Transit Position.

Transfer Position is where the disc is moved vertically to the correct play height.

Actual Player is the position at which the disc should be on the CD Spindle.

If no errors are displayed there are no errors that this program can yet find.

Summary of Errors

E01	-	Faulty Eprom
E10	-	Faulty Ram DS 1643
E11	-	68hc11 Ram Fail
E40	-	Rogue Value in Credit Table
E50	-	Coin Stuck in Mech./Rejected Last Coin
E60	-	Can't play Track 1 Disc 101
E70	-	Can't detect Clamp Open
E71	-	Can't find bottom Opto
E72	-	Can't find Sync Opto
E73	-	Count not on at Sync Position
E74	-	Sync found at wrong position
E75	-	Count not on at new position
E76	-	Can't find up (middle Opto)
E77	-	Can't find top
E78	-	Can't find down (middle Opto)
E79	-	Can't detect clamp closed
E81	-	Wallbox1 shorted
E82	-	Wallbox2 shorted
E83	-	Wallbox3 shorted
E84	-	Keyboard input bit stuck
E85	-	Coin input bit stuck
E86	-	Middle Opto blocked when it shouldn't be
E87	-	Top Opto blocked when it shouldn't be
E88	-	Bottom Opto blocked when it shouldn't be

17.7 LASER PLAYER FITTING / ALIGNMENT

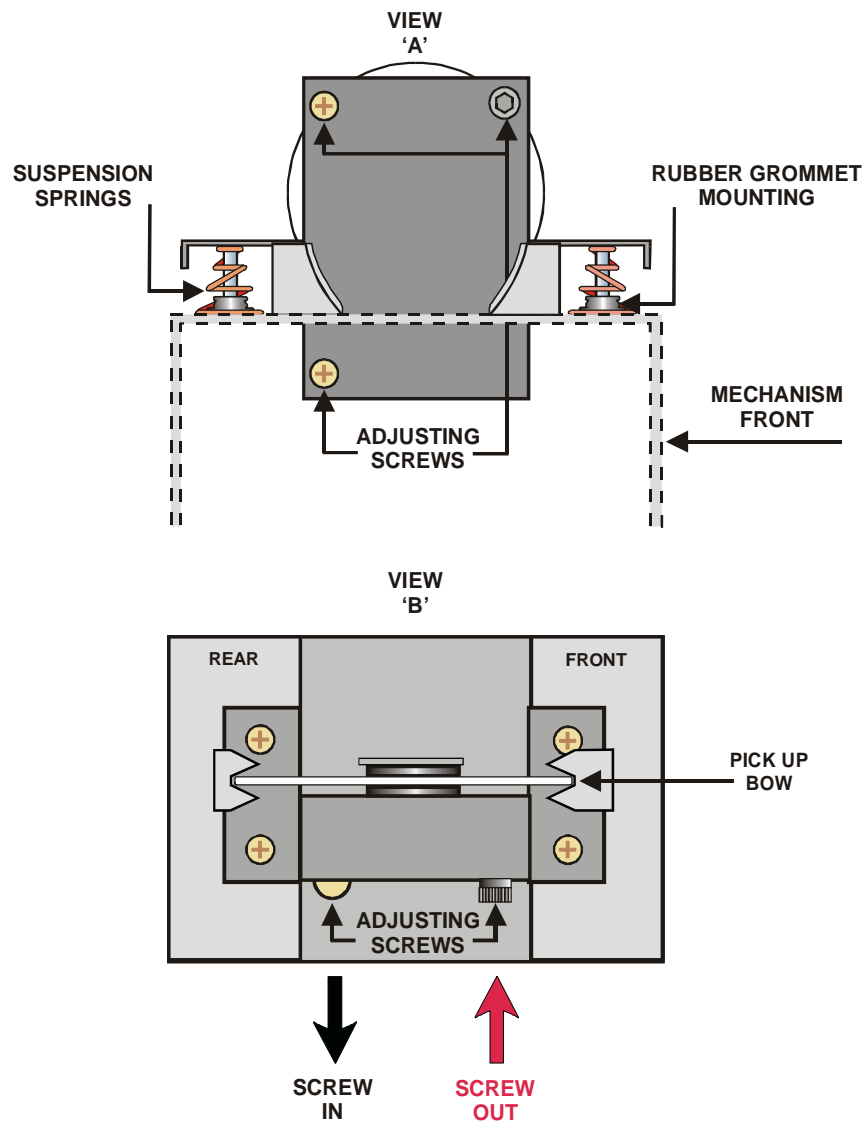

FITTING NEW (REPLACEMENT) DECK

1. Check deck mounting rubbers are fitted in base.
2. Insert deck into mounting rubbers.
3. Connect red, green and black leads to Distribution Board A.
4. Connect Clamp motor lead to Distribution B.
5. Fit disk into clamped position.
6. Check that the disk runs free. There should be a little play back and forth in the Clamp Arm.
7. Bring C.D lift shoe (pick up bow) over disc and align disc to shoe, via adjusting screws on side of deck. The two back adjusting screws (Pozi-drive) must both be adjusted equally in or out, the third front adjusting screw (socket drive) can be adjusted independently to correct the angle at which the deck lies.
8. **Check deck does not move when disc is being removed during operation (up, or down). If it does refer to manual page 44 'resting play position'.**

18. DISC POPULARITY (BASIC SYSTEM)

Open the door (Machine switches to Service Mode)

Current Disc is rejected

Pickup assembly moves to central position

Press the collectors button (White push button)

The display will show the least played disc of paid play

The track shown is the number of plays for that disc (E is for error disc)

The credits shown is the chart number of the least played paid play.

NOW

Press Key C to remove the displayed disc to the player

Remove the disc from the player by hand

Insert the new disc into the empty slot (not player)

OR

Press Key 1 to move up the chart towards No. 1 (most played)

OR

Press Key 2 to move down the chart towards least played.

Repeat above to carry out the disc changes.

Close the door.

The machine will return to normal operation.

On entering this mode the least played paid disc is displayed.

The popularity is calculated on all discs, including paid plays in the BGM band.

Take care when using Cancel to remove a disc because it may be in the BGM Band 1.

19. DATA RETRIEVAL

SIMPLE DATARET 'Ensure' DIL SW 5 OFF & DIL SW 6 OFF
on SLE1000 Board

Fetch least played disc.

PSION DATARET (DIL SW 5 ON - DIL SW 6 OFF)

CON 11 - RX --- 3 - 25 WAY D FEMALE (SOCKET)
TX --- 2
OV --- 7
17V --- 25

Collecting Data.

Open Door
Connect up PSION
Press Collector Button (Inside Machine)
Machine Parks
Turn on PSION and press J (B) except when installing (usual way)
PSION collects data
Enter cash in PSION
Unplug PSION
Press collector button again (display shows disc 159 chart position 60)
Change discs using 1,2 and cancel as per basic system
Collect Cash
Close door

Installing Site Number

Open the door.
Connect up Psion.
Press Collector Button. *Machine parks.*
Turn on Psion and press I (install)
Enter your password in the Psion.
Psion reads current Site Number.
Enter your required Site Number to be installed.
Check the password and press Y if correct , N if not correct and re-enter.
Unplug Psion.
Close door.

BACTA DATARET (5 ON and 6 ON)

CON 11 - RX --- 3 - 25 WAY D FEMALE (SOCKET)
TX --- 2
OV --- 7
17V --- 25

Open Door
Connect up Collector Unit
Press Collector Button
Machine Parks
Initiate the collector unit to collect the data (or install site number)
Unplug Collector Unit
Press Collector Button again (Display shows disc 159 chart position 60)
Change discs using 1,2 and Cancel as per basic system
Collect cash
Close door

BLMS Fender Cartridge System. (DIL SW 5 OFF - DIL SW 6 ON)

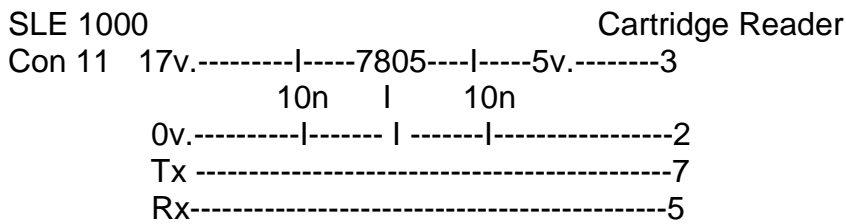

Set DIL Switches to BLMS Cartridge

To collect data
Turn Machine on
Open door
Press collector button
Wait for LED 4 on cartridge reader to stop flashing
Turn Machine off
Remove cartridge
Close door
Turn machine on

M.H.G. Dataret (8 Entered in menu 5 level 5)

Con 11-	Rx	---	2	-	25 way "D" Female (socket)
	Tx	---	3		
	0v	---	7		
	17v	---	13		

Open door

Connect up collector unit

Press collector button

Machine parks

Initiate the collector unit

Press collector button again (Display shows Disc 159 chart position 60)

Change discs using 1.2 and cancel as per system

Collect cash

Close door

20. LED BAR GRAPH_ (on SLE1000 Board)

PIN 1 END

CD9V	-	CDM12 9Vdc Power Supply (come on 2 secs after power on)
CD5V	-	CDM12 5Vdc Power Supply
30	-	30V Power Supply for Stepper Motors
AC	-	Indication of (12-0-12)v.AC Supply
R1	-	Wallbox 1 RX (Active when transmission is received from w/box)
R2	-	Wallbox 2 RX (Active when transmission is received from w/box)
R3	-	Wallbox 3 RX (Active when transmission is received from w/box)
T1	-	Wallbox 1 TX (Active when transmission is sent to w/box)
T2	-	Wallbox 2 TX (Active when transmission is sent to w/box)
T3	-	Wallbox 3 TX (Active when transmission is sent to w/box)

21. TITLE RACK CONTROLLER (SLE 1011A Issue 2)

CON1 - POWER

1 ----- 12v A.C
2 ----- 0v
3 ----- 12v A.C

CON 2 - PAGE END LIMIT MICROSWITCHES

1 ----- Page End Right M/S
2 ----- Page End Left M/S
3 ----- 0v
4 ----- N/C
5 ----- N/C

CON3 - MOTOR

1 ----- Motor Microswitch
2 ----- 0v
3 ----- Motor
4 ----- Motor

CON4 - LEFT/RIGHT BUTTONS

1 ----- 12v
2 ----- 12v
3 ----- 0v
4 ----- 0v
5 ----- Left Button
6 ----- Right Button

DIL SWITCH:

1 OFF = Attract Mode every 5 minutes
 ON = Attract Mode every 10 minutes

2 3 Page Motor speeds
OFF OFF Slowest speed
ON OFF Slow speed
OFF ON Fast speed
ON ON Fastest speed

4 OFF Attract Mode on.
 ON Attract Mode off.

NOTE: If the LED remains permanently lit then it indicates a "fault" of either a faulty motor or a page is jammed in the middle of turning.

22. LUBRICATION

21 st Century Mechanism.

Over a period of time it may be necessary to clean and relubricate with "**LINEAR LUBE**" (Thomson), the vertical and the horizontal guide shafts.

CDM 12 Ind.

Lubrication Points CDM 12 Ind

1 & 2

Add on the sledge guidance shaft one dot of Tribol 9098 grease on each side of the sledge.

3 & 4

Add on the sledge guidance plane one dot of Tribol 9098 grease on each side of the sledge. (Place grease dot 4 as close as you can in the middle).

5

Press down the sledge spring and add a drop of Tribol 9098 grease on the spring.

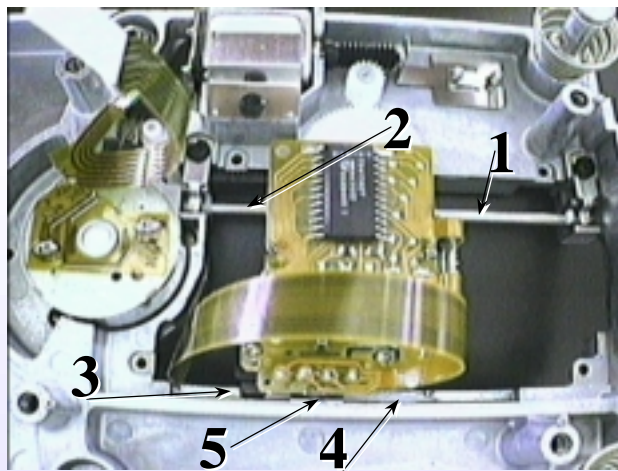

Note: Move the sledge by turning the sledge motor gear.
Never by moving the sledge by hand. This will damage the toothed bar and gears!!!

Philips
Key
Modules



PHILIPS

Lubrication Points CDM 12 Ind

6

Add one dot of Tribol 9098 grease between pivotspring and worm.

7

Add one dot of Tribol 9098 grease between worm and idler wheel.

8

Add one dot of Tribol 9098 grease between idler wheel and gear wheel.

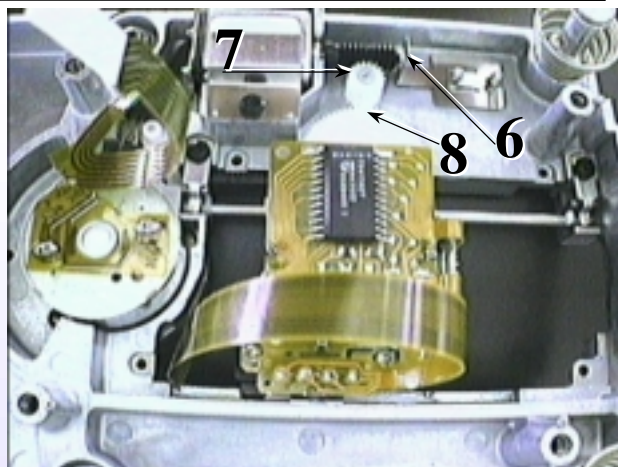

Philips
Key
Modules



PHILIPS

Lubrication Points CDM 12 Ind

9

Add 2 dots of Tribol 9098 grease on the guidance plane at each side of the spring.

10

Add 2 dots of Tribol 9098 grease on the sledge guidance shaft between the two bearing holes

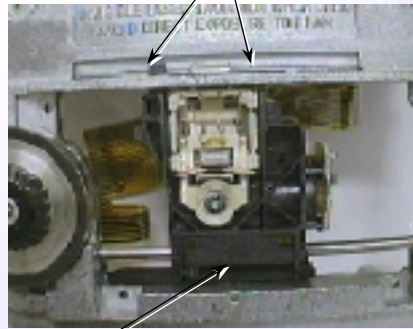

10

Philips
Key
Modules



PHILIPS

23. LENS CLEANING INSTRUCTIONS FOR CDM 12 IND

The actuator lens of the CDM 12 Industrial Mechanism is an optical component in the system that is exposed to the environment. The environment in the Juke-Box application is not comparable with normal home use. For example the nicotine from cigarette smoke can soil the lens. This can influence the playability of the system enormously and cleaning of the lens is necessary.

Before you touch the lens we advise, making the surface of the lens clean by blowing clean air over it in order to avoid little particles making scratches on the lens.

Because the material of the lens is synthetic and coated with a special anti-reflective layer, the cleaning must be done with a non-aggressive cleaning fluid.

We advise you to use the following lens cleaner which is available in a normal photo shop ' **KODAK LENS CLEANER**'.

The actuator is a very precise mechanical component, that has to follow the tracks with a pitch of $1.6 \mu\text{m}$. and must not be damaged in order to guarantee its full function.

We advise you to clean gently (don't press too hard) the lens with a soft and clean cotton tip moistened with the special lens cleaner.

The direction of cleaning must be in this way.

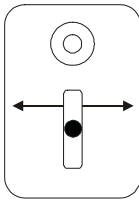

Lens cleaning

WARNING

Actuator is very fragile

Lens is made of special material with a coating. Do not scratch or damage

Clean carefully

Smoke and dust soils the lens

Moisten a clean cue tip with a solution of 25% Iso propanol (IPA).
Place the tip on the lens and press down carefully.
Wipe carefully in the direction (perp to the sledge direction) so that the actuator doesn't move.
Dry up with a dry cue tip

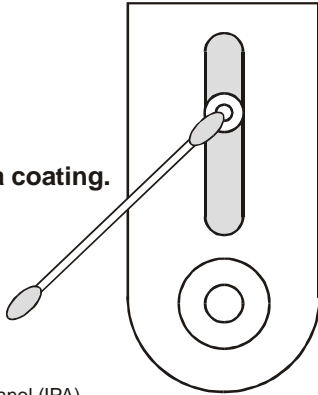

 **PHILIPS**